



# QUICK INDEX

## PLIERS:

	Page No.
Angle Nose .....	6, 8
Battery .....	10
Belt Plier Pouch .....	12
Bent Nose Slip Joint .....	7
Brake Adjusting Tools .....	11
Brake Spring .....	11
Convertible Retaining Ring .....	14, 15
Electrical Wire Stripper .....	16
Hose Clamp Plier .....	7
Lock Ring .....	11
<b>Pipe Wrench Plier</b> ® .....	5
Plier Sets .....	12, 13
Retaining Ring .....	14, 15, 16
Slip Joint (Straight Nose) .....	7
Snap Ring Set .....	16
Solid Joint (Diagonal's, Lineman's, Needle Nose, End Nipper) .....	9
Toggle Lock (Standard and Long Nose) .....	10
Tongue & Groove (C-Joints) .....	4

## PUNCHES & CHISELS:

Cape Chisel .....	19
Center Punch .....	21
Cold Chisel .....	18
Diamond Point Chisel .....	18
Lining Up Bar .....	21
Long Cold Chisel .....	18
Long Pin Punch .....	20
Long Taper Punch .....	20
Pin Punch .....	20
Prick Punch .....	21
Pry Bars .....	22
Punch & Chisel Sets .....	23, 24
Rivet Buster .....	19
Roll Spring Punch .....	25
Round Nose Chisel .....	19
Solid Punch .....	21

## WRENCHES:

Adjustables .....	40
Battery Wrench .....	37
Combination (Fractional and Metric) .....	34
Ignition .....	35
<b>OFF-SET</b> Ratcheting Box .....	38, 39
Ratcheting Box .....	36, 37
Refrigeration Ratchets .....	37
Sockets .....	28, 29, 30, 31, 32, 33

## SCREWDRIVERS:

4 in 1 (Miniature and Standard Size) .....	43
Nut Driver (Fractional and Metric) .....	44
Phillips .....	42
Screw Starters .....	45
Sets .....	43
Slotted .....	42
Spark Testing Screwdriver (In Wrench Section) .....	35
Torx® .....	45
Wooden Handle Slotted & Phillips .....	43

## PLUMBING & INDUSTRIAL TOOLS:

## Page No.

Aviation Snips .....	55
Ball Tip L-Hex Key Wrench .....	52
Extractors .....	53
Faucet Handle Pullers .....	48
Flaring .....	50
Hack Saw .....	51
Hammers (Claw, Ball Pein, BRASS) .....	53
Hex Key Sets (+Fold-up Set) .....	52
Hex Key Wrenches .....	52
Internal Pipe Wrenches .....	49
Metal Cutting Snips .....	55
Pipe Wrenches .....	49
Sledges .....	54
T-Handle Hex Key Wrench .....	52
Tape Measures .....	48
Torch Lighter .....	51
Tubing Cutters .....	50

## AUTOMOTIVE TOOLS:

Ball Joint Separator .....	63
Feeler Gauges .....	35, 65
Glaze Breakers .....	59
Hones .....	58
Oil Filter Wrenches .....	61
Piston Ring Expander .....	64
Pullers .....	62, 63
Ring Compressors .....	64
Ring Groove Cleaner .....	64
Tie Rod End Puller .....	63
Valve Lifters .....	60, 61

## SERVICE TOOLS:

Awls .....	71
Axle Rethreading Die .....	72
Battery Carrier .....	72
Blow Guns .....	68
Contact Point File .....	72
Cotter Key Extractors .....	71
Dust Cap Plier .....	72
Flexible Drivers .....	72
Headlight Spring Tool .....	71
Hook and Pick Set .....	70
Hose Clamp Pliers .....	72
Inspection Mirrors .....	69
Magnetic Pick-Up Tools .....	70
Mechanical Finger .....	70
Scrapers .....	71

## DISPLAY BOARDS .....

## FORMS:

Conversion Table .....	75
Literature Order Form .....	77
Logo .....	74
Tool Order Form .....	76

## INDEX:

Numerical .....	79-80
-----------------	-------

PLIERS  
PUNCHES, CHISELS  
& PRY BARS  
WRENCHES  
SCREWDRIVERS  
PLUMBING &  
INDUSTRIAL  
AUTOMOTIVE  
SERVICE TOOLS  
DISPLAYS

## THE ORIGINAL ANGLE NOSE PLIER

Some 75 years ago in Kansas City, Missouri two brothers, Paul and Otto Froeschl, thought of a new idea for the ordinary straight nose plier; angle the nose 32 degrees to create the greater leverage and gripping power that a straight nose plier is unable to give. Thus was born the original WILDE WRENCH, the first angle nose plier, granted U.S. Patent No. 1,800,447, and the beginning for the two brothers of over forty years experience in the designing and manufacturing of pliers and other quality hand tools.

During this time, the name WILDE has become synonymous with fine quality hand tools and for many years our trademark was



"THE PLIERSMITHS™". The original WILDE WRENCH is as practical and useful today as it was over fifty years ago, a testimony to the soundness of the idea and the design which produced the first angle nose plier.

Today, the third and fourth generation offspring of the founders are still in the business of producing quality pliers and other hand tools. The original WILDE WRENCH is still available, together now with a wide variety of other pliers and hand tools shown in this catalog.

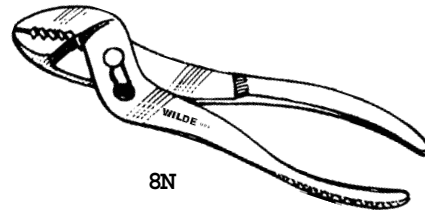
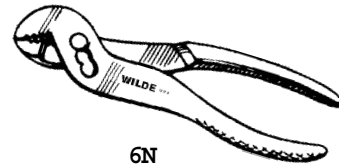

---

THE **WILDE**® LINE  
THE **WITCO**® LINE



Wilde Tool offers a complete line of Slip Joint Pliers. All pliers are drop forged from our own special alloy steel. Precision heat treating assures the toughest tool available. Some pliers are also available in Industrial Black.

Our pliers are finished with one of two finishes. The **WILDE**® line is full polished. The **WITCO**® line is the same precision pliers as the **WILDE**® line with polishing operations eliminated to make these pliers attractive in price without sacrificing quality. Comfortable plastic fluorescent orange grips are standard equipment on all **WITCO**® pliers.



# PLIERS

## WILDE® WITCO® UNDERCUT TONGUE & GROOVE PLIERS

Jaws are milled with deep, self-gripping pipe wrench style teeth. Accurately machined tongue fits and pivots in any of the precision machine grooves eliminating strain and wear on the bolt.

See page 4. Plier Set Page 12.

## WILDE® WITCO® SLIP JOINT PLIERS BENT, THIN & STRAIGHT NOSE

Extra hard, deep, sharply cut teeth for greater grip and longer wear.

Lobster claw teeth design provides two gripping sections, one is extra wide for large objects, the other for small work. All pliers have hardened alloy steel bolt and all have shear wire cutters.

See Page 7. Plier Set Page 12.

## WILDE® WITCO® ANGLE NOSE PLIERS

Jaws are milled with deep, self-gripping pipe wrench style teeth. Hardened bolts. The 10" and 11" are equipped with Grip Tight Clips™ which pull the bolt into positive alignment in slot when plier is under pressure. The 11" has notch in teeth which fits vertical rib on basket strainer nut as well as hub caps and dust covers.

Includes Wilde Wrench, the original angle nose plier.

See Pages 6, 8. Plier Set Page 12.

## LOCK RING PLIERS

These solid joint pliers spread snap lock rings on brakes, transmissions, farm equipment and machine tools. Drop forged and polished jaws. Jaws are scored on outside to hold rings securely. Points are not guaranteed.

See Page 11.

BELT PLIER POUCH. See Page 12.

LOCKING PLIERS. See Page 10.

BRAKE SPRING PLIERS. See Page 11.

BRAKE ADJUSTERS. See Page 11.



## NEW HEAVY DUTY PIPE WRENCH PLIER®

UNDERCUT Tongue & Grooves. Jaws are offset 90°. 20% more leverage. Forged from alloy steel. Heavy duty construction. Fully heat treated. Reach where other pliers will not go.

See Page 5. DISPLAY SETS - Page 13.

## HOSE CLAMP PLIER

Produced from our 8" style slip joint plier. Plastic grips. Lobster claw style offers gripping section and has shear type cutter. 3 tools in one.

See Page 7.

## SOLID JOINT PLIERS

Forged from selected steel, individually paired tempered, adjusted and tested. Keen cutting edge. Polished face with plastic grips.

See Page 9.

## BATTERY PLIERS

Fixed joint self-gripping plier. Three sets of teeth engage the work giving additional holding power on round rods or worn battery bolts. Plastic grips. Polished jaw.

See Page 10.

## RETAINING RING PLIERS

For easy removal or installing retaining rings over shafts or in boxes. Internal or external. Straight tips or bent.

See Pages 14, 15, & 16.

## CONVERTIBLE RETAINING RING PLIER

Accurate alignment for tough alloy steel replaceable tips. Precision plier jaws and pivot. Push button convertible from ext. to int. action. Spring return plier handles. Five color coded pairs of tips in sizes .036, .047, and .070 straight and bent 90° in a small durable plastic pouch with hex wrench. Master pouch for convenient storage. Heavy duty cushion grips.

See Page 15. Plier Sets Page 16.

PLIERS

PUNCHES, CHISELS  
& PRY BARS

WRENCHES

SCREWDRIVERS

PLUMBING &  
INDUSTRIAL

AUTOMOTIVE

SERVICE TOOLS

DISPLAYS

# WILDE® WITCO® TONGUE & GROOVE PLIERS

PLASTIC GRIPPED HANDLES ARE INTENDED FOR COMFORT & FIRM GRIP. THEY ARE NOT INTENDED FOR PROTECTION AGAINST ELECTRIC SHOCK.

MACHINED UNDERCUT TONGUE & GROOVES RE-ENFORCEMENT WEBS

PLIERS  
PUNCHES, CHISELS & PRY BARS  
WRENCHES  
SCREWDRIVERS  
PLUMBING & INDUSTRIAL  
AUTOMOTIVE  
SERVICE TOOLS  
DISPLAYS

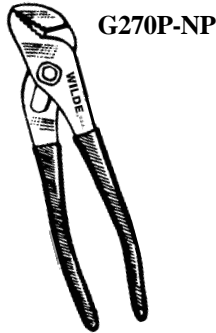

G270P-NP

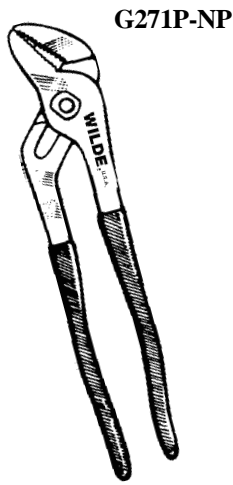

G271P-NP

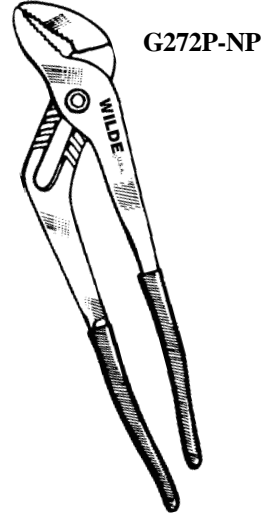

G272P-NP

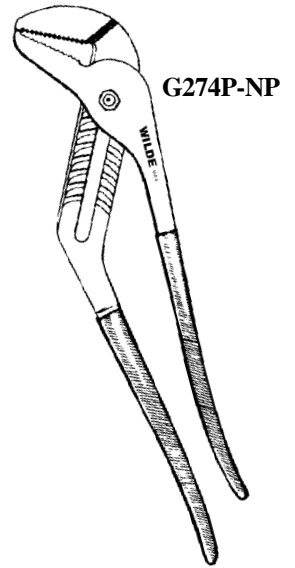

G274P-NP

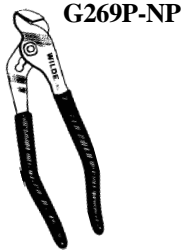

G269P-NP

## WILDE® NATURAL FINISH. FULL POLISHED.

CAT. NO.	OAL	# OF ADJUST- MENTS	MAX. PAR. JAW OPENING	INFORMATION	GRIPS	# OF MAX. PAR. STD. CARDED PACK	
						PACK	STD.
G269P-NP	5"	3	1/2"	T&G Ignition Plier	Red	X	10
G270P-NP	7"	5	7/8"	General Purpose	Red	X	10
G271P-NP	10"	5	1-1/2"	Most Popular	Red	X	5
G272P-NP	12-3/4"	7	2-5/8"	When size is needed	Red	X	4
G274P-NP	16"	11	4-1/4"	Even more size	Red		1
G276P-NP	20-1/4"	14	5-3/4"	3-1/4" Throat Depth	Red		Available Soon

## WITCO® INDUSTRIAL BLACK. SATIN FINISHED.



G269B

G269B	5"	3	1/2"	T&G Ignition Plier	Flourescent Orange	X	10
G270B	7"	5	7/8"	General Purpose	Flourescent Orange	X	10
G271B	10"	5	1-1/2"	Most Popular	Flourescent Orange	X	5
G272B	12-3/4"	7	2-5/8"	When size is needed	Flourescent Orange	X	4
G274B	16"	11	4-1/4"	Even more size	Flourescent Orange	X	1
G276B	20-1/4"	14	5-3/4"	3-1/4" Throat Depth	Flourescent Orange		Available Soon



G270B



G271B



G272B

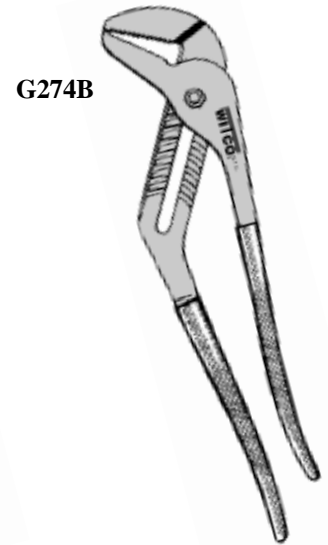

G274B

# WILDE® WITCO® PIPE WRENCH PLIERS®

PLASTIC GRIPPED HANDLES ARE INTENDED FOR COMFORT & FIRM GRIP. THEY ARE NOT INTENDED FOR PROTECTION AGAINST ELECTRIC SHOCK.

## Pipe Wrench Plier®

MACHINED UNDERCUT TONGUE & GROOVES RE-ENFORCEMENT WEBS

### Pipe Wrench Style Teeth

Jaws Angle 90°  
To Create up to 20% more leverage than conventional 32° angled jaws.

G295P-NP

G295's are with Smooth Jaws

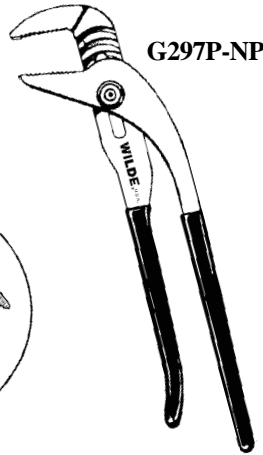
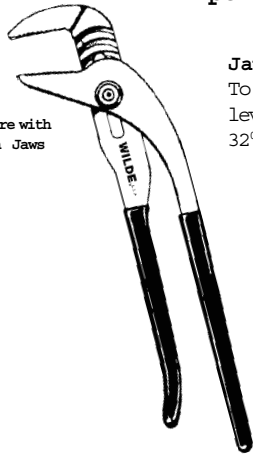

G297P-NP

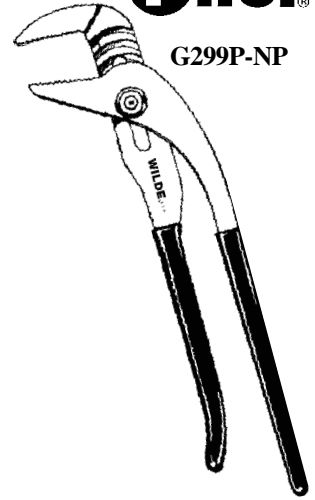

G299P-NP

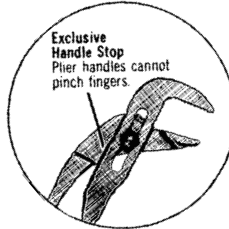

Exclusive Handle Stop Plier handles cannot pinch fingers.

G293P-NP



## WILDE® NATURAL FINISH. FULL POLISHED.

CAT. NO.	OAL	# OF ADJUST- MENTS	MAX. PAR. JAW OPENING	MACHINED T&G GRIPS		STD. CARDED	PACK
				Undercut	Red		
G293P-NP	7"	4	7/8"	Undercut	Red	X	10
G295P-NP	10"	7	2-1/8"	Undercut-Smooth Jaw	Red	X	5
G297P-NP	10"	7	2-1/8"	Undercut	Red	X	5
G299P-NP	12-3/4"	7	2-5/8"	Undercut	Red	X	5

## WITCO® INDUSTRIAL BLACK. SATIN FINISHED.

G293B



G293B	7"	4	7/8"	Undercut	Flourescent Orange	X	10
G295B	10"	5	2-1/8"	Undercut-Smooth Jaw	Flourescent Orange	X	5
G297B	10"	5	2-1/8"	Undercut	Flourescent Orange	X	5
G299B	12-3/4"	7	2-5/8"	Undercut	Flourescent Orange	X	5

G295B



G295's are with Smooth Jaws

G297B



G299B



# WILDE® WITCO® ANGLE NOSE SLIP JOINT PLIERS

PLASTIC GRIPPED HANDLES ARE INTENDED FOR COMFORT & FIRM GRIP.  
THEY ARE NOT INTENDED FOR PROTECTION AGAINST ELECTRIC SHOCK.

**NOTCHED:**  
Fits Vertical Rib  
Basket Strainer Nut.

Also Auto Hub Dust  
Covers & Hub Caps.

GRIP TIGHT  
CLIP™

G251P-NP

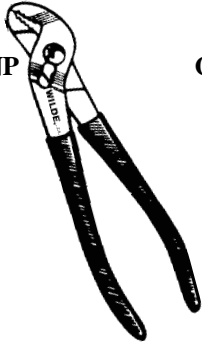

G252P-NP

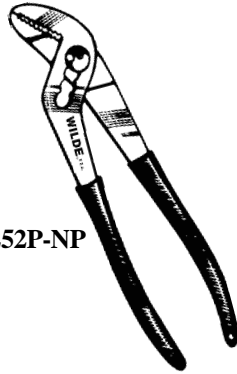

G253P-NP

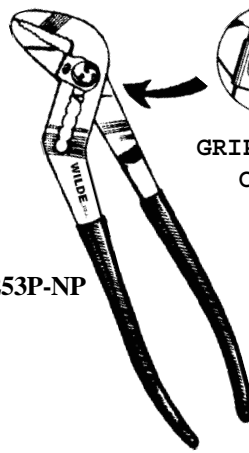

G254P-NP

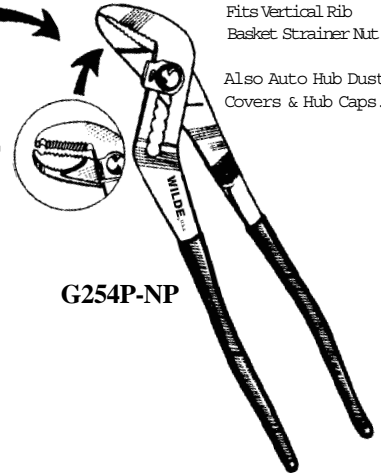

## WILDE® NATURAL FINISH. FULL POLISHED.

G250P-NP

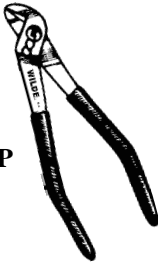

CAT NO.	# OF ADJUST- MENTS	MAX. PAR. JAW OPENING	PLIERS: ANGLE		STD. CARDED PACK
			NOSE SLIP JOINT	GRIPS	
G250P-NP	5"	3	1/2"	Ignition.	Red X 10
G251P-NP	6-3/4"	3	3/4"	All Purpose.	Red X 10
G252P-NP	8"	4	1-1/8"	All Purpose.	Red X 10
G253P-NP	10"	7	2-1/8"	Water Pump.	Red X 5
G254P-NP	11"	7	2-1/8"	Notched Nose.	Red X 5

## WITCO® INDUSTRIAL BLACK. SATIN FINISHED.

G250B



G250B	5"	3	1/2"	Ignition.	Flourescent Orange	X	10
G251B	6-3/4"	3	3/4"	All Purpose.	Flourescent Orange	X	10
G252B	8"	4	1-1/8"	All Purpose.	Flourescent Orange	X	10
G253B	10"	7	2-1/8"	Water Pump.	Flourescent Orange	X	5
G254B	11"	7	2-1/8"	Notched Nose.	Flourescent Orange	X	5

GRIP TIGHT  
CLIP™

G251B



G252B



G253B



G254B

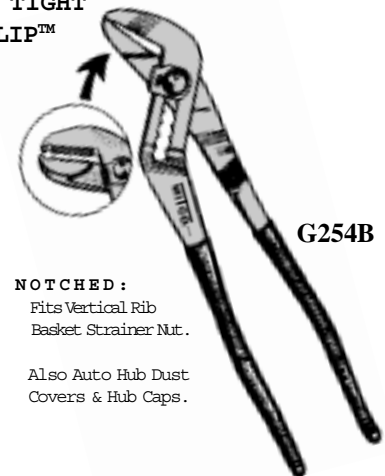

**NOTCHED:**  
Fits Vertical Rib  
Basket Strainer Nut.

Also Auto Hub Dust  
Covers & Hub Caps.

PLIERS

PUNCHES, CHISELS  
& PRY BARS

WRENCHES

SCREWDRIVERS

PLUMBING &  
INDUSTRIAL

AUTOMOTIVE

SERVICE TOOLS

DISPLAYS

# WILDE® WITCO® COMBINATION/SLIP JOINT PLIERS

PLASTIC GRIPPED HANDLES ARE INTENDED FOR COMFORT & FIRM GRIP.  
THEY ARE NOT INTENDED FOR PROTECTION AGAINST ELECTRIC SHOCK.

All pliers with  
SHEAR TYPE CUTTERS



On all pliers on this page



G261BP-NP

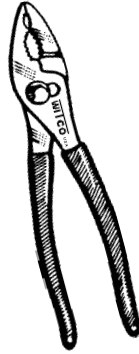

G262P-NP

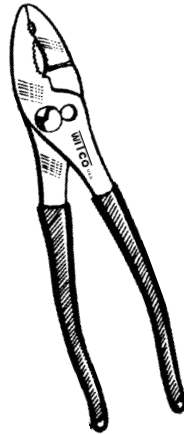

G263P-NP

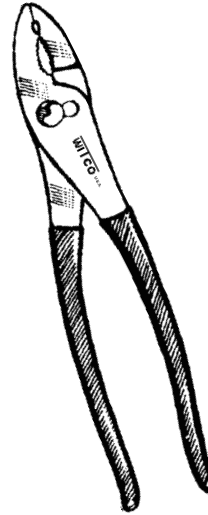

G264P-NP

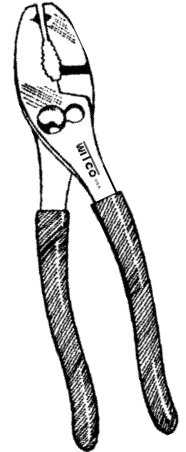

G260P-NP

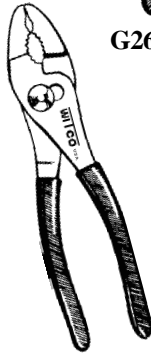

G261TP-NP

## WILDE® NATURAL FINISH. FULL POLISHED.

CAT NO.	OAL	# OF ADJUST-MENTS	ADDITIONAL INFORMATION	GRIPS	STANDARD CARDED	PACK
G261TP-NP	6-1/2"	2	THIN NOSE.	Red	X	10
G261BP-NP	6-1/2"	2	BENT NOSE.	Red	X	10
G262P-NP	6-1/2"	2	Shear Type Cutter.	Red	X	10
G263P-NP	8"	2	Shear Type Cutter	Red	X	10
G264P-NP	10"	2	Shear Type Cutter	Red	X	5
G260P-NP	8"	2	HOSE CLAMP.	Red	X	10

## WITCO® INDUSTRIAL BLACK. SATIN FINISHED.



G261TB

G261TB	6-1/2"	2	THIN NOSE.	Flourescent Orange	X	10
G261BB	6-1/2"	2	BENT NOSE.	Flourescent Orange	X	10
G262B	6-1/2"	2	Shear Type Cutter.	Flourescent Orange	X	10
G263B	8"	2	Shear Type Cutter	Flourescent Orange	X	10
G264B	10"	2	Shear Type Cutter	Flourescent Orange	X	5
G260B	8"	2	HOSE CLAMP.	Flourescent Orange	X	10



G261BB



G262B



G263B



G264B



G260B



# WILDE® KNURLED HANDLE & SMOOTH JAW ANGLED NOSE SLIP JOINT PLIERS

PLASTIC GRIPPED HANDLES ARE INTENDED FOR COMFORT & FIRM GRIP.  
THEY ARE NOT INTENDED FOR PROTECTION AGAINST ELECTRIC SHOCK.

PLIERS

PUNCHES, CHISELS  
& PRY BARS

WRENCHES

SCREWDRIVERS

PLUMBING &  
INDUSTRIAL

AUTOMOTIVE

SERVICE TOOLS

DISPLAYS

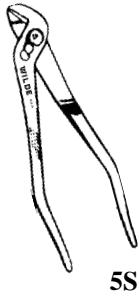

5S

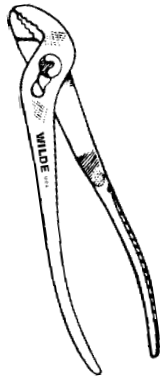

7G

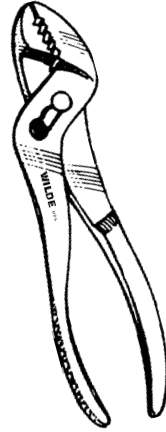

8N  
G8N

ORIGINAL WILDE WRENCH

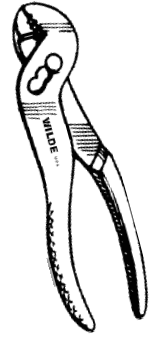

6N  
G6N

## WILDE® NATURAL FINISH.

CAT NO.	OAL	# OF ADJUST- MENTS	MAX. PAR. JAW OPENING	INFORMATION	HANDLE	STD. CARDED	PACK
5S	5"	3	1/2"	Full Polish. Ignition.	Plain Handle	X	10
7G	6-3/4"	3	3/4"	Full Polish.	Knurled	X	10
				All Purpose Plier.			
6N	6"	3	7/8"	Full Polish.	Knurled	X	10
G6N	6"	3	7/8"	Full Polish.	Gripped	X	10
8N	8"	3	1-1/8"	Full Polish.	Knurled	X	10
G8N	8"	3	1-1/8"	Full Polish.	Gripped	X	10
10S	10"	7	2-1/8"	Satin Finish.	Knurled	X	5
				Water Pump Plier w/ <b>GRIP TIGHT CLIP™</b>			
11S	11"	7	2-1/8"	Satin Finish.	Knurled	X	5
				Water Pump Plier w/ <b>GRIP TIGHT CLIP™</b>			
G428N-NP	10"	7	2-1/8"	Smooth Jaw.	Red Grips	X	5
				Full Polish. Water Pump Plier w/ <b>GRIP TIGHT CLIP™</b>			

GRIP TIGHT  
CLIP™

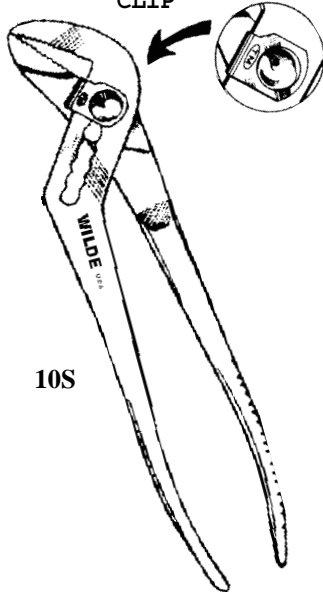

10S

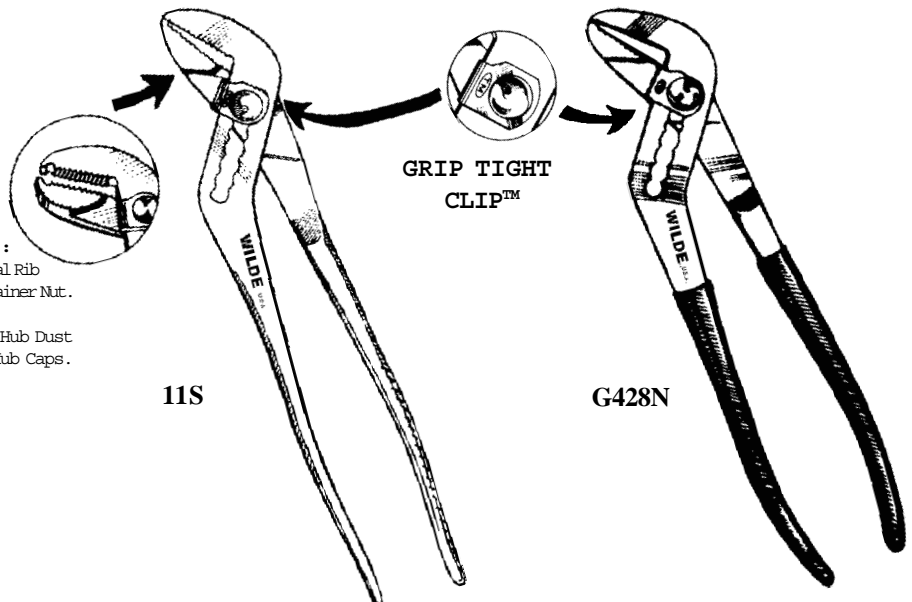

11S

G428N

NOTCHED :  
Fits Vertical Rib  
Basket Strainer Nut.

Also Auto Hub Dust  
Covers & Hub Caps.

# WILDE® SOLID JOINT PLIERS

PLASTIC GRIPPED HANDLES ARE INTENDED FOR COMFORT & FIRM GRIP.  
THEY ARE NOT INTENDED FOR PROTECTION AGAINST ELECTRIC SHOCK.

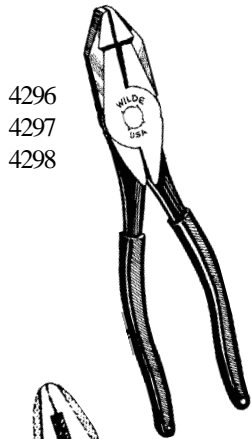

4296  
4297  
4298

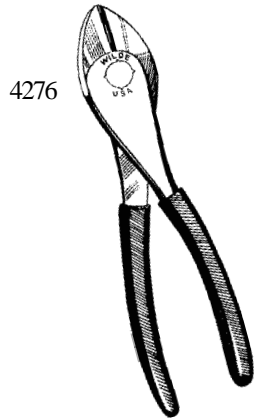

4276

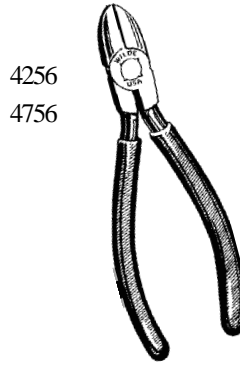

4256  
4756

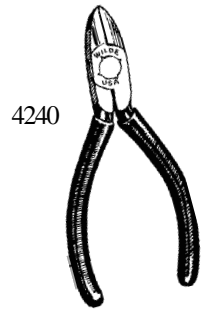

4240

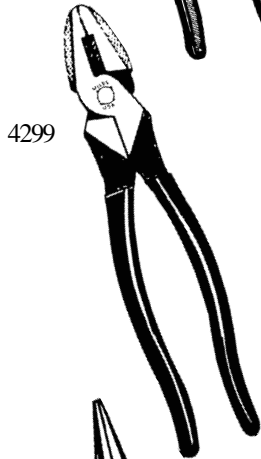

4299

## WILDE® NATURAL FINISH.

CAT NO.	OAL	INFORMATION	GRIPS	STANDARD	STD. CARDED PACK	STD. 10
4240	4-3/4"	Diagonal Cutting Plier.	Red	X	10	
4256	6"	Diagonal Cutting Plier.	Red	X	10	
4756	7-1/2"	Diagonal Cutting Plier.	Red	X	10	
4276	7"	<b>Heavy Duty</b> Diagonal Cutting Plier.	Red	X	10	
4296	6-1/2"	Lineman's Plier.	Red	X	10	
4297	7-1/4"	Lineman's Plier.	Red	X	10	
4298	8-1/2"	Lineman's Plier	Red	X	10	
4299	9"	Lineman's <b>NEW ENGLAND</b> style High Leverage.	Red	X	10	
4225	5"	Short Needle Nose Plier w/ <b>Cutter</b> .	Red	X	10	
4227	6-1/2"	Needle Nose Plier w/ <b>Cutter</b> .	Red	X	10	
4226	6"	<b>CURVED</b> Needle Nose Plier.	Red	X	10	
4278	7-3/4"	Duck Bill Plier.	Red	X	10	
4287	7"	End Nippers.	Red	X	10	

4225



4227



4226

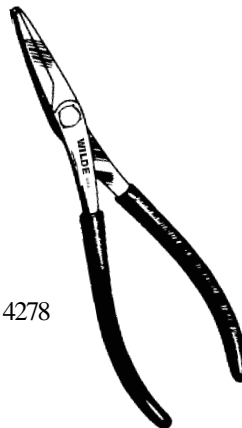

4278

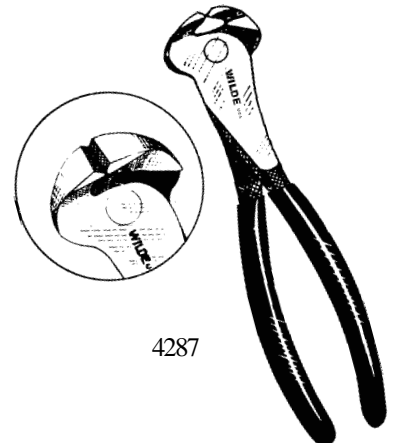

4287

PLIERS  
PUNCHES, CHISELS & PRY BARS  
WRENCHES  
SCREWDRIVERS  
PLUMBING & INDUSTRIAL  
SERVICE TOOLS  
AUTOMOTIVE  
DISPLAYS



# WILDE® BATTERY & LOCKING PLIERS

PLASTIC GRIPPED HANDLES ARE INTENDED FOR COMFORT & FIRM GRIP.  
THEY ARE NOT INTENDED FOR PROTECTION AGAINST ELECTRIC SHOCK.

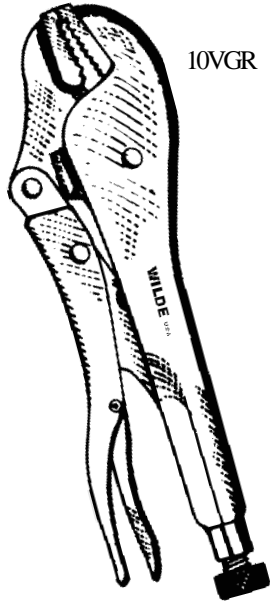

10VGR

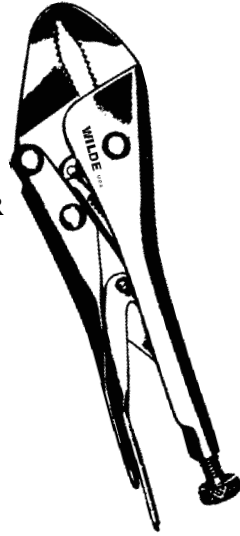

7VGR



G410B

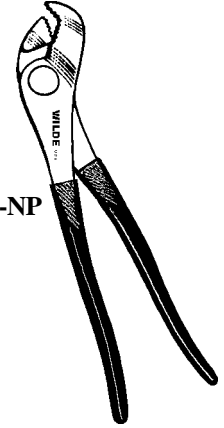

G410P-NP

## WILDE®

CAT. NO.	OAL	INFORMATION	GRIPS	STANDARD	STOCKED
				PACK	
G410P-NP	7-1/2"	Battery Plier. Fixed Joint. 3 Sets of Teeth. Full Polished. <b>Natural Finish.</b>	Red	X	10
G410B	7-1/2"	Battery Plier. Fixed Joint. 3 Sets of Teeth. Full Polished. <b>Industrial Black.</b>	Red	X	10
7VGR	7"	Locking Toggle Loc Plier. Plated. Thin involute jaws will grip rounds up to 1" diameter.		X	5
10VGR	10"	Locking Toggle Loc Plier. Plated. 1-1/4" Maximum Opening.		X	5
4VGR	4"	<b>Long Nose</b> Locking Toggle Loc Plier w/Cutter. Plated. Reaches into close quarters.		X	5
6VGR	6"	<b>Long Nose</b> Locking Toggle Loc Plier w/Cutter. Plated. Reaches into close quarters.		X	5
9VGR	9"	<b>Long Nose</b> Locking Toggle Loc Plier w/Cutter. Plated. Reaches into close quarters.		X	5



4VGR

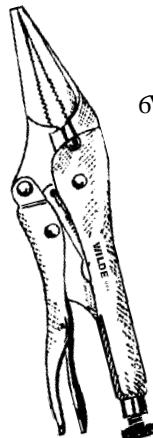

6VGR

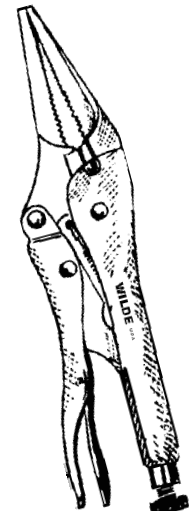

9VGR

PLIERS

PUNCHES, CHISELS & PRY BARS

WRENCHES

SCREWDRIVERS

PLUMBING & INDUSTRIAL

AUTOMOTIVE

SERVICE TOOLS

DISPLAYS

# WILDE® LOCK RING PLIERS & BRAKE TOOLS

PLASTIC GRIPPED HANDLES ARE INTENDED FOR COMFORT & FIRM GRIP.  
THEY ARE NOT INTENDED FOR PROTECTION AGAINST ELECTRIC SHOCK.

Heavy Duty with parallel action jaws feature compound leverage action. Spring action closes jaws. Thin jaws are notched to securely hold snap lock rings as they open in a parallel plane. Used on transmissions, brakes and machine tools.

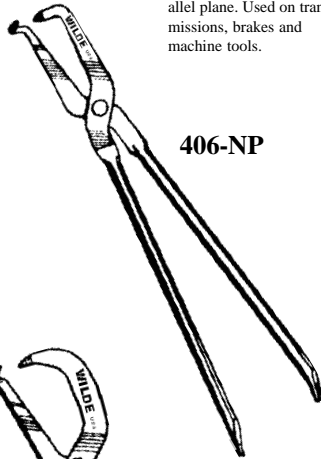

406-NP

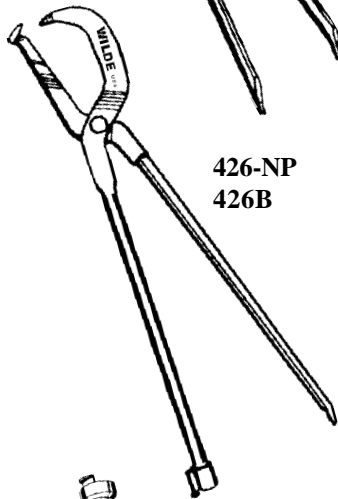

426-NP  
426B

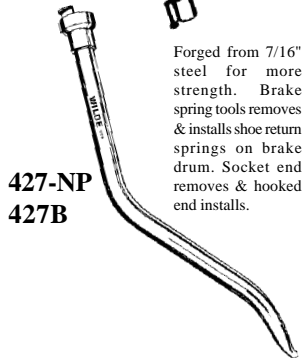

427-NP  
427B

Forged from 7/16" steel for more strength. Brake spring tools removes & installs shoe return springs on brake drum. Socket end removes & hooked end installs.

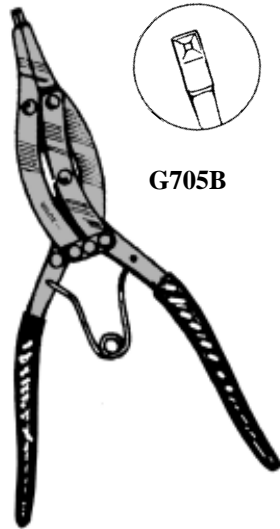

G705B

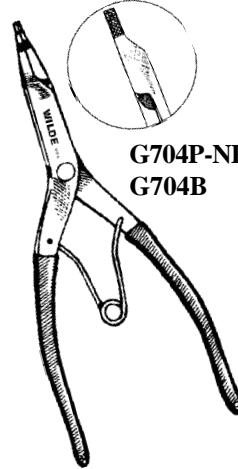

G704P-NP  
G704B

Lock Ring Pliers are single piece drop forging for strength. Spreads, removes & installs ring w/o holes. Deep knurled jaws hold rings. Spring action closes jaw used on brakes, transmissions, pedal shifts, clutch shafts & machine tools. Can also be used to spread piston rings.

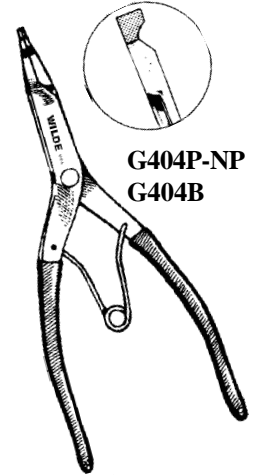

G404P-NP  
G404B

## WILDE® NATURAL FINISH.

CAT NO.	OAL	OPENING	INFORMATION	GRIPS	CARDED	STD. PACK
G404P-NP	9"	1-1/2"	Right Angle Tip Lock Ring Plier.	Red	X	5
G704P-NP	9"	1-1/2"	Straight Tip Lock Ring Plier.	Red	X	5
406-NP	13-1/2"		Brake Spring Plier		X	5
426-NP	14"		Bendix Brake Spring Plier.		X	5
427-NP	9"		Brake Spring Tool. Socket & Spoon End.		X	10
587T-NP	8"		Brake Adjuster.		X	10
577-NP	8"		Brake Adjuster.		X	10
577T-NP	6-3/4"		Brake Adjuster w/Notch Portion.		X	10

## INDUSTRIAL BLACK

G404B	9"	1-1/2"	Right Angle Tip Lock Ring Plier.	Flourescent Orange	X	5
G704B	9"	1-1/2"	Straight Tip Lock Ring Plier.	Flourescent Orange	X	5
G705B	10"		Compound Lev. Lock Ring Plier.	Red	X	5
426B	14"		Bendix Brake Spring Plier.		X	5
427B	9"		Brake Spring Tool. Socket & Spoon End.		X	10
587TB	8"		Brake Adjuster.		X	10
577B	8"		Brake Adjuster.		X	10
577TB	6-3/4"		Brake Adjuster w/Notch Portion.		X	10

Adjusts clearance between brake drum & brake shoe. Fits through slot in backing plate & turns star wheel. Heads are offset for hard to reach areas.

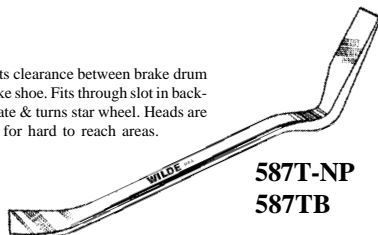

587T-NP  
587TB

Angled blade with NOTCHED portion. Heads are offset for hard to reach areas.

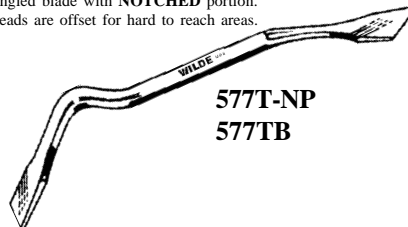

577T-NP  
577TB

Designed to adjust brakes where space is limited.

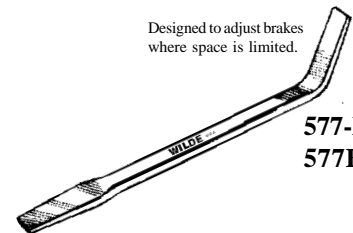

577-NP  
577B



PLIERS  
PUNCHES, CHISELS & PRY BARS  
WRENCHES  
SCREWDRIVERS  
PLUMBING & INDUSTRIAL  
AUTOMOTIVE  
SERVICE TOOLS  
DISPLAYS

# WILDE® PLIER SETS

Cat.  
No.

Description

St.  
Pk.

*PLASTIC GRIPPED HANDLES ARE INTENDED FOR COMFORT & FIRM GRIP.  
THEY ARE NOT INTENDED FOR PROTECTION AGAINST ELECTRIC SHOCK.*



G259SPD

2-Piece Clear Hang-Up Vinyl Pouch Set. This All-Purpose set consists of one each G271P-NP Tongue and Groove Plier & G262P-NP Combination/Slip Joint Plier. **NATURAL FINISH.**

2 Pcs.  
10/Pk.

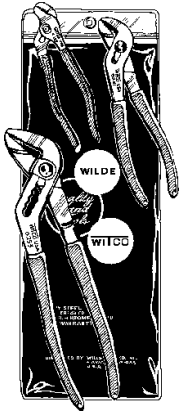

G256SPD

3-Piece Clear Hang-Up Vinyl Pouch Set. Set consists of one each G250P-NP, G251P-NP and G253P-NP Slip Joint Angle Nose Pliers. **NATURAL FINISH.**

3 Pcs.  
10/Pk.

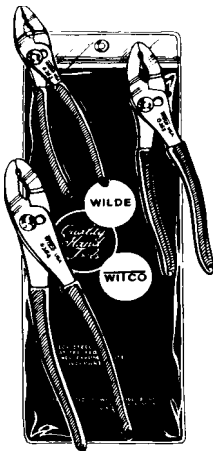

G258SPD

3-Piece Clear Hang-Up Vinyl Pouch Set. Set consists of one each G262P-NP, G263P-NP & G264P-NP Combination/Slip Joint Pliers. **NATURAL FINISH.**

3 Pcs.  
10/Pk.

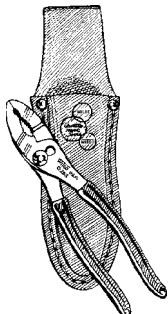

A67

Belt Plier Pouch Only. **Heavy Duty** top grain leather. Tunnel belt loop fits 2-1/8" belt. Double rivet reinforcement.

10

**#A67 Pouch Fits All Tools On Page 7.**

PLIERS

PUNCHES, CHISELS  
& PRY BARS

WRENCHES

SCREWDRIVERS

PLUMBING &  
INDUSTRIAL

AUTOMOTIVE

SERVICE TOOLS

DISPLAYS



PIPE WRENCH PLIER® SETS

Cat.  
No.

Description

St.  
Pk.

PLASTIC GRIPPED HANDLES ARE INTENDED FOR COMFORT & FIRM GRIP.  
THEY ARE NOT INTENDED FOR PROTECTION AGAINST ELECTRIC SHOCK.

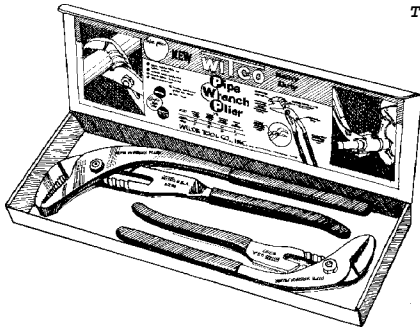

G292SPB

2-Piece Display Box.  
Set consists of one  
G297P-NP and G299P-NP  
PIPE WRENCH PLIER®  
NATURAL FINISH.

2 Pcs.  
10/Pk.



G292SPD

2-Piece Clear Hang-Up.  
Vinyl Pouch Set.  
Set consists of one  
G297P-NP and G299P-NP  
PIPE WRENCH PLIER®  
NATURAL FINISH.

2 Pcs.  
10/Pk.



G297SP

20-Piece Display Box.  
10"-90° Pipe Wrench Plier® .  
7 Machined Tongue & Groove  
adjustments. Maximum  
parallel jaw opening 2-1/8".  
Plastic Grips.  
NATURAL FINISH.

20  
Pcs.



G299SP

15-Piece Display Box.  
12-3/4"-90° Pipe Wrench  
Plier® . 7 Machined  
Tongue & Groove adjustments.  
Maximum parallel jaw  
opening 2-5/8".  
Plastic Grips.  
NATURAL FINISH

20  
Pcs.

PLIERS

PUNCHES, CHISELS  
& PRY BARS

WRENCHES

SCREWDRIVERS

PLUMBING &  
INDUSTRIAL

AUTOMOTIVE

SERVICE TOOLS

DISPLAYS



# PLIERS- WILDE®

Cat. No. Description St. Pk.

PLIERS  
PUNCHES, CHISELS & PRY BARS  
WRENCHES  
SCREWDRIVERS  
PLUMBING & INDUSTRIAL  
AUTOMOTIVE  
SERVICE TOOLS  
DISPLAYS

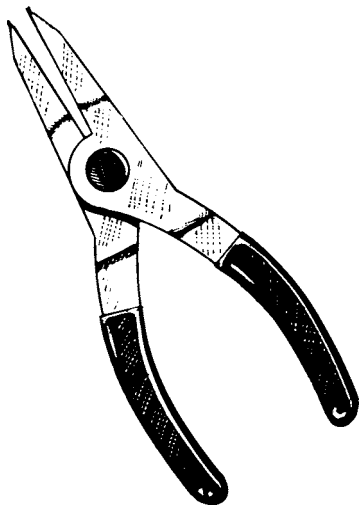

520	Internal Retaining Ring Plier.	.022 Tip dia.	5
520A	Internal Retaining Ring Plier.	.022 Tip dia. 45°	5
520B	Internal Retaining Ring Plier.	.022 Tip dia. 90°	5
521	Internal Retaining Ring Plier.	.038 Tip dia.	5
521A	Internal Retaining Ring Plier.	.038 Tip dia. 45°	5
521B	Internal Retaining Ring Plier.	.038 Tip dia. 90°	5
522	External Retaining Ring Plier.	.038 Tip dia.	5
522A	External Retaining Ring Plier.	.038 Tip dia. 45°	5
522B	External Retaining Ring Plier.	.038 Tip dia. 90°	5
523	Internal Retaining Ring Plier.	.070 Tip dia.	5
523A	Internal Retaining Ring Plier.	.070 Tip dia. 45°	5
523B	Internal Retaining Ring Plier.	.070 Tip dia. 90°	5
524	External Retaining Ring Plier.	.070 Tip dia.	5
524A	External Retaining Ring Plier.	.070 Tip dia. 45°	5
524B	External Retaining Ring Plier.	.070 Tip dia. 90°	5
525	Internal Retaining Ring Plier.	.090 Tip dia.	5
525A	Internal Retaining Ring Plier.	.090 Tip dia. 45°	5
525B	Internal Retaining Ring Plier.	.090 Tip dia. 90°	5
526	External Retaining Ring Plier.	.115 Tip dia.	5
526A	External Retaining Ring Plier.	.115 Tip dia. 45°	5
526B	External Retaining Ring Plier.	.115 Tip dia. 90°	5

## Convertible Retaining Ring Pliers

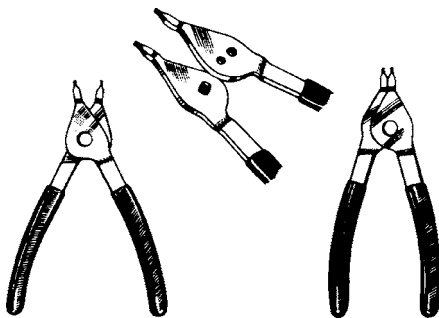

	Tip Size	Tip Angle	OAL	
527	.038	Straight	6"	5
527A	.038	45°	6"	5
527B	.038	90°	6"	5
528	.047	Straight	6"	5
528A	.047	45°	6"	5
528B	.047	90°	6"	5
534	.070	Straight	7-3/4"	5
534A	.070	45°	7-3/4"	5
534B	.070	90°	7-3/4"	5
535	.090	Straight	9-1/2"	5
535A	.090	45°	9-1/2"	5
535B	.090	90°	9-1/2"	5

# PLIERS- WILDE®

Cat. No.	Description	St. Pk.
----------	-------------	---------

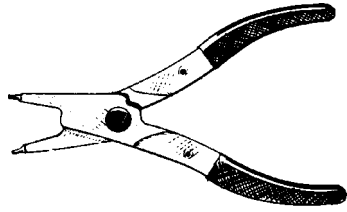

542	External Retaining Ring Plier. Spring loaded. Angle tips, size .045.	10
-----	--	----

TO BE DISCONTINUED  
WHEN STOCK  
IS DEPLETED

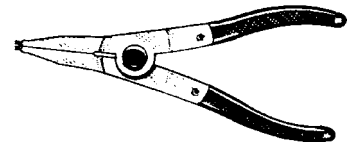

563	Internal Retaining Ring Plier. Spring loaded. Straight tips, size .060.	10
-----	---	----

564	External Retaining Ring Plier. Spring loaded. Straight tips, size .060.	10
-----	---	----

PLIERS

PUNCHES, CHISELS  
& PRY BARS

WRENCHES

SCREWDRIVERS

PLUMBING &  
INDUSTRIAL

AUTOMOTIVE

SERVICE TOOLS

DISPLAYS

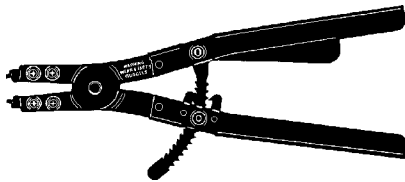

517	Internal Retaining Ring Plier 15-11/16" long. Tip dia. .120. Tips opened 3-3/16". Tips closed 11/16".	3
-----	---	---

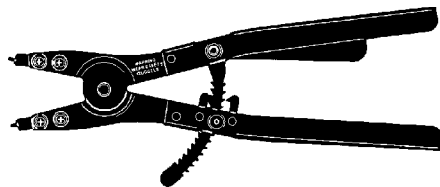

518	External Retaining Ring Plier 15-3/4" long. Tip dia. .120. Tips opened 3-1/8". Tips closed 1/2".	3
-----	--	---

517TS	Replacement Tips-Straight	5
517T-45	Replacement Tips-45°	5
517T-90	Replacement Tips-90°	5

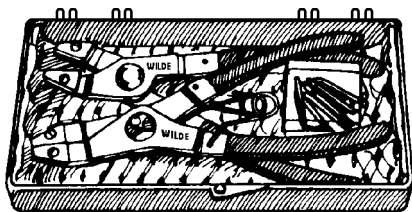

444K	Snap Ring Plier Set. 1 Pair Tips Each .038 Black-Straight, 15°, 45° & 90°. .047 Silver-Straight, 45° & 90°. .070 Gold-Straight.	10
------	--	----

444T	Tips Only for 444K	5
------	--------------------	---

444I	Internal Plier with tips.	5
------	---------------------------	---

444E	External Plier with tips.	5
------	---------------------------	---

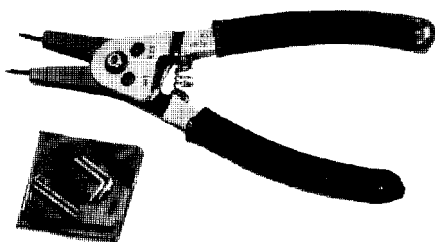

1234	Convertible Retaining Ring Plier. Ext. sizes 1/4" thru 2". Int. sizes 3/8" thru 2".	5
------	---	---

1214	Replacement Tips for #1234 .036 Black-Straight & 90°. .047 Silver-Straight & 90°. .070 Copper-Straight.	5
------	--	---



# PLIERS

Cat.  
No.

Description

St.  
Pk.

540

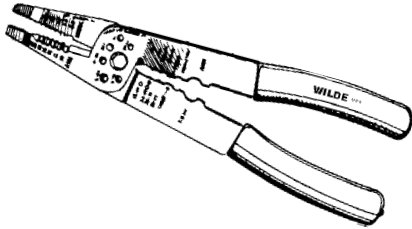

Electrical Wire Stripper - AWG 5 & Metric, Full 1/2" Scissor Type Cutting Blades - Stripping Stations for 22 to 10 and .5MM to 5.3MM - Perfect Rethread Bolt Cutting on 6/32 - 8/32 - 10/32 plus 3.5MM, 4MM, 5MM. Crimping of both Insulated and Non-insulated Terminals - also 7-8MM Auto Ignition - Overall Length of 9-1/2" provides proper leverage - complete with air cushion vinyl grips.

541



Electrical Wire Stripper. AWG & Metric. Automatic return spring. Convenient handle lock. Hardened Steel pivot bushing. Wire sizes are embossed in metal. Strip sizes: AWG 20 to 10 Metric 0.8 to 2.6

537

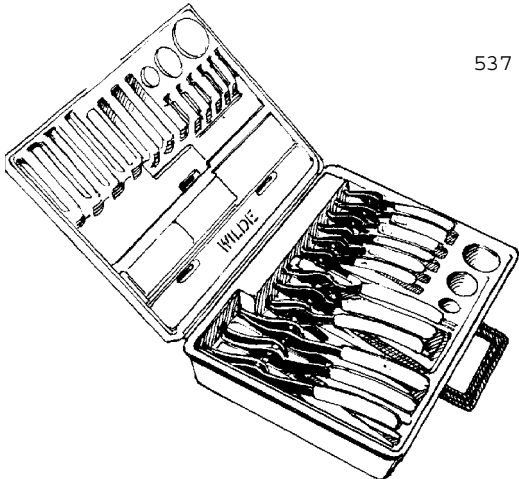

Professional Dozen - Retaining Ring Plier Kit. Kit covers complete range of rings from approximately 1/4" to 3-1/2" of both Internal and External types - 12 convertible pliers tip diameters .038 - .047 - .070 - .090 with straight - 45° and 90° bend. (Takes the place of 24 individual models.) Comfortable vinyl grips - packed in shock resistant plastic case with storage space for spare rings complete with carrying handle. Weight - 5-1/2 pounds.

538

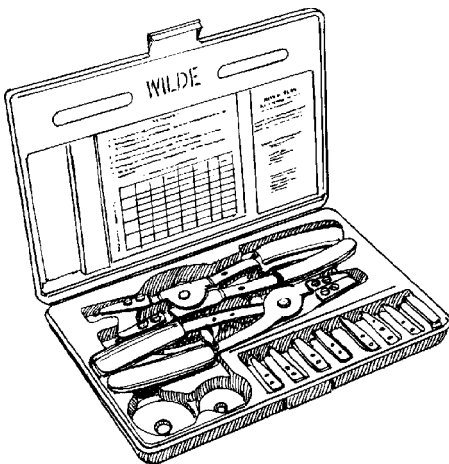

Heavy Duty Plier Set. Includes Replaceable Tip Retaining Ring Pliers with spring, ratchet lock assembly, 27R (Internal) and 28R (External) in form fit plastic storage case with spaces for spare rings. Kit contains eight (8) pairs of tips - Diameter .108 Black: Straight - 15° - 45° - 90°; also .120 Silver: Straight - 15° - 45° - 90° - tips are mounted directly to the pliers for maximum stability - Pliers 9-1/2" long, black oxide finish and red air cushion grips - two pliers take the place of sixteen (16) separate pliers. Weight - 2-1/2 pounds.

PLIERS

PUNCHES, CHISELS & PRY BARS

WRENCHES

SCREWDRIVERS

PLUMBING & INDUSTRIAL

AUTOMOTIVE

SERVICE TOOLS

DISPLAYS



# HEX STOCK PUNCHES & CHISELS

## NEW NATURAL FINISH & INDUSTRIAL BLACK PLATE

COLD CHISELS  
LONG COLD CHISELS  
CAPE CHISELS  
ROUND NOSE CHISELS  
DIAMOND POINT CHISELS

RIVET BUSTER  
PIN PUNCHES  
LONG PIN PUNCHES  
CENTER PUNCHES  
PRICK PUNCHES

SOLID PUNCHES  
LONG TAPER PUNCHES  
LINING UP BARS  
PRY BARS

PRY BARS with Handles (Industrial Black)

AND A

COMPLETE LINE OF  
PUNCH & CHISEL SETS

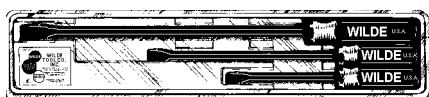

## ROLL SPRING PUNCHES

Each Wilde Roll Spring Punch has a pilot point that fits into the hollow center of the pin, holding the driving shoulder of the punch in perfect contact position. Pins are quickly and easily removed without damage to wall of hole or pin.

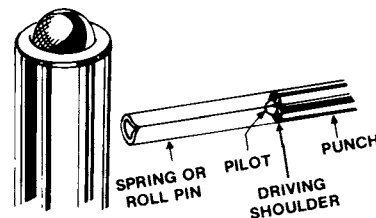

### PUNCHES, CHISELS & PRY BARS

All punches and chisels are forged from High Carbon Molybdenum Tool Steel. Properly heat treated to make these tools the toughest on the market. Punches and Chisels are hardened the entire length with tempered striking end. The heads and points are full polished, stock is satin finished for positive grip. The cutting edges are sharpened and re-sharpened to give the keenest points available. The punches are centerless ground to ensure complete accuracy. **Pin punches have a reverse taper point which eliminates the punch from sticking in the work piece.**

Thirteen popular sets are available packaged in sturdy vinyl pouches.

When looking for quality punches and chisels, professionals look for **WILDE**.

### PROPER USE

Punches and Chisels are designed to be resharpened once they become dull. Care should be taken that excessive heat is not obtained when re-sharpening. If the grinding temperature is not controlled the hardness can be taken out of the immediate area. More importantly a hard, brittle surface can be set up which is very susceptible to fracture.

Always wear **safety goggles** when using punches and chisels.

Pin punches are designed to drive a work piece out only after the work piece has been started out with a solid or long taper punch - avoid side pressure.

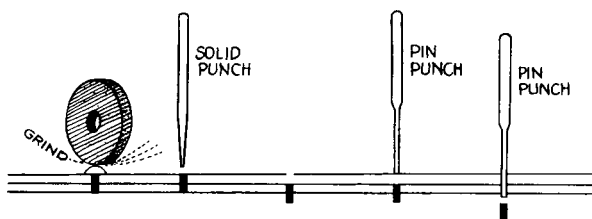

PLIERS  
PUNCHES, CHISELS & PRY BARS  
WRENCHES  
SCREWDRIVERS  
PLUMBING & INDUSTRIAL  
AUTOMOTIVE  
SERVICE TOOLS  
DISPLAYS

# CHISELS

HEX STOCK

Cat. No.

Cut

Length Approx.

Stock Size

St. Pk.

## COLD CHISELS

### NATURAL FINISH

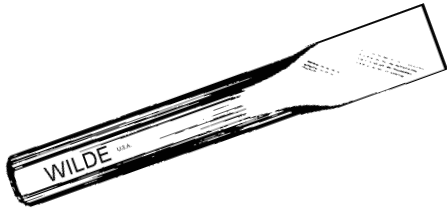

CC832	1/4	4-3/4	1/4	20
CC1032	5/16	5	5/16	20
CC1232	3/8	5-1/4	5/16	20
CC1432	7/16	5-1/2	3/8	20
CC1632	1/2	6	3/8	20
CC2032	5/8	6-1/2	1/2	15
CC2432	3/4	7	5/8	10
CC2832	7/8	7-1/2	3/4	10
CC3232	1	8	7/8	5
CC3632	1-1/8	8	7/8	5

### INDUSTRIAL BLACK

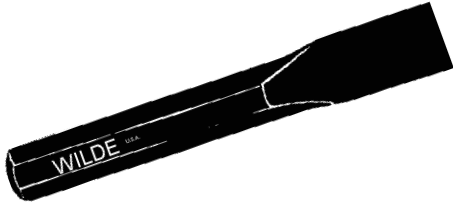

CC832B	1/4	4-3/4	1/4	20
CC1032B	5/16	5	5/16	20
CC1232B	3/8	5-1/4	5/16	20
CC1432B	7/16	5-1/2	3/8	20
CC1632B	1/2	6	3/8	20
CC2032B	5/8	6-1/2	1/2	15
CC2432B	3/4	7	5/8	10
CC2832B	7/8	7-1/2	3/4	10
CC3232B	1	8	7/8	5
CC3632B	1-1/8	8	7/8	5

## EXTRA LENGTH COLD CHISELS

### NATURAL FINISH

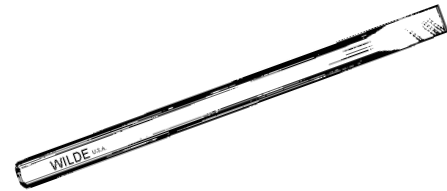

CCL1632	1/2	12	3/8	10
CCL2032	5/8	12	1/2	10
CCL2432	3/4	12	5/8	5
CCL2432-14	3/4	14	5/8	5
CCL2432-18	3/4	18	5/8	5
CCL2832	7/8	12	3/4	5
CCL3232	1	12	7/8	5
CCL3232-18	1	18	7/8	5

### INDUSTRIAL BLACK

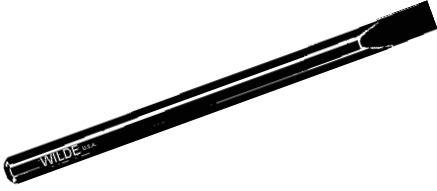

CCL1632B	1/2	12	3/8	10
CCL2032B	5/8	12	1/2	10
CCL2432B	3/4	12	5/8	5
CCL2432-14B	3/4	14	5/8	5
CCL2432-18B	3/4	18	5/8	5
CCL2832B	7/8	12	3/4	5
CCL3232B	1	12	7/8	5
CCL3232-18B	1	18	7/8	5

## DIAMOND POINT CHISEL

### NATURAL FINISH

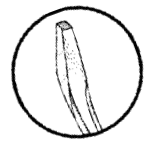

CD432	1/8	4-1/2	1/4	20
CD532	5/32	5	5/16	20
CD632	3/16	5	3/8	20
CD832	1/4	6	3/8	20
CD1032	5/16	6	1/2	20
CD1232	3/8	6-1/2	5/8	10
CD1632	1/2	7	3/4	10
CD2032	5/8	8	7/8	5

### INDUSTRIAL BLACK



CD432B	1/8	4-1/2	1/4	20
CD532B	5/32	5	5/16	20
CD632B	3/16	5	3/8	20
CD832B	1/4	6	3/8	20
CD1032B	5/16	6	1/2	20
CD1232B	3/8	6-1/2	5/8	10
CD1632B	1/2	7	3/4	10
CD2032B	5/8	8	7/8	5

### Diamond Point Chisels

Designed to cut V-grooves & clean out inside corners.

PLIERS  
PUNCHES, CHISELS & PRY BARS  
WRENCHES  
SCREWDRIVERS  
PLUMBING & INDUSTRIAL  
AUTOMOTIVE  
SERVICE TOOLS  
DISPLAYS

<b>CHISELS</b>	<b>HEX STOCK</b>	<b>Cat. No.</b>	<b>Cut</b>	<b>Length Approx.</b>	<b>Stock Size</b>	<b>St. Pk.</b>
----------------	------------------	-----------------	------------	-----------------------	-------------------	----------------

**CAPE CHISELS**

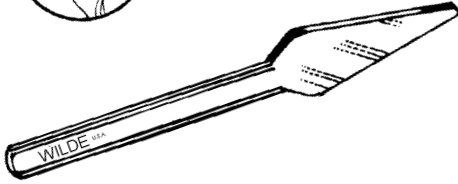
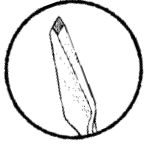

**NATURAL FINISH**

CP632	3/16	5	1/4	20
CP732	7/32	5	5/16	20
CP832	1/4	5-1/2	3/8	20
CP1032	5/16	6	3/8	20
CP1232	3/8	6-1/2	1/2	20

**Cape Chisels**  
Designed for cutting keyways, slots, and grooves in metal.

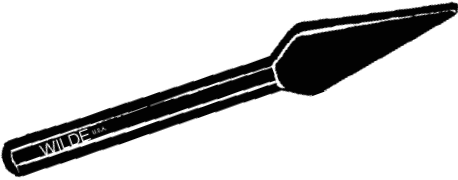

**INDUSTRIAL BLACK**

CP632B	3/16	5	1/4	20
CP732B	7/32	5	5/16	20
CP832B	1/4	5-1/2	3/8	20
CP1032B	5/16	6	3/8	20
CP1232B	3/8	6-1/2	1/2	20

**ROUND NOSE CHISELS**

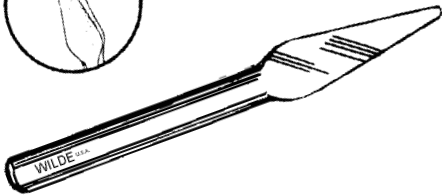
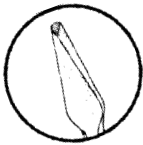

**NATURAL FINISH**

CR432	1/8	4-1/2	1/4	20
CR632	3/16	5	1/4	20
CR732	7/32	5	5/16	20
CR832	1/4	5-1/2	3/8	20
CR1032	5/16	6	3/8	10
CR1232	3/8	6-1/2	1/2	10
CR1632	1/2	8	3/4	10

**Round Nose Chisels**  
aka Half Round Chisels.  
Designed for cutting grooves in metal where an oval or U shape is desired.

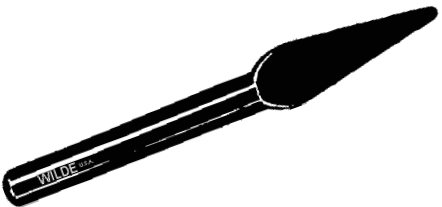

**INDUSTRIAL BLACK**

CR432B	1/8	4-1/2	1/4	20
CR632B	3/16	5	1/4	20
CR732B	7/32	5	5/16	20
CR832B	1/4	5-1/2	3/8	20
CR1032B	5/16	6	3/8	10
CR1232B	3/8	6-1/2	1/2	10
CR1632B	1/2	8	3/4	10

**RIVET BUSTER**



**NATURAL FINISH**

RB2432	3/4	12	5/8	10
--------	-----	----	-----	----



**INDUSTRIAL BLACK**

RB2432B	3/4	12	5/8	10
---------	-----	----	-----	----



# PUNCHES

HEX STOCK

Cat. No.

Cut

Length Approx.

Stock Size

St. Pk.

## PIN PUNCHES

### NATURAL FINISH

PP232	1/16	4-1/4	5/16	20
PP564	5/64	4-1/2	5/16	20
PP332	3/32	4-3/4	5/16	20
PP432	1/8	5	5/16	20
PP532	5/32	5-1/4	5/16	20
PP632	3/16	5-1/2	5/16	20
PP732	7/32	7	3/8	20
PP832	1/4	7	3/8	20
PP1032	5/16	7	1/2	20
PP1232	3/8	7	1/2	20

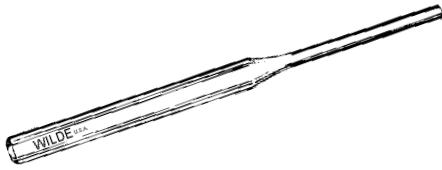

### INDUSTRIAL BLACK

PP232B	1/16	4-1/4	5/16	20
PP564B	5/64	4-1/2	5/16	20
PP332B	3/32	4-3/4	5/16	20
PP432B	1/8	5	5/16	20
PP532B	5/32	5-1/4	5/16	20
PP632B	3/16	5-1/2	5/16	20
PP732B	7/32	7	3/8	20
PP832B	1/4	7	3/8	20
PP1032B	5/16	7	1/2	20
PP1232B	3/8	7	1/2	20



## LONG PIN PUNCHES

### NATURAL FINISH

PPL432	1/8	8	5/16	20
PPL532	5/32	8	5/16	20
PPL632	3/16	9	1/2	20
PPL732	7/32	9	1/2	20
PPL832	1/4	9	1/2	20
PPL1032	5/16	9	1/2	20
PPL1232	3/8	9	1/2	20

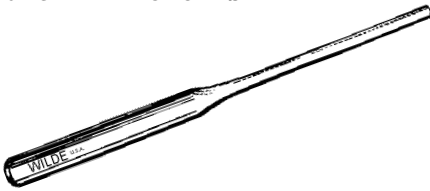

### INDUSTRIAL BLACK

PPL432B	1/8	8	5/16	20
PPL532B	5/32	8	5/16	20
PPL632B	3/16	9	1/2	20
PPL732B	7/32	9	1/2	20
PPL832B	1/4	9	1/2	20
PPL1032B	5/16	9	1/2	20
PPL1232B	3/8	9	1/2	20

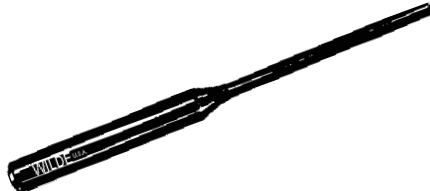

## LONG TAPER PUNCHES

### NATURAL FINISH

PLT232	1/16	7	3/8	20
PLT332	3/32	7-1/2	3/8	20
PLT432	1/8	8	3/8	20
PLT532	5/32	8-1/2	1/2	20
PLT632	3/16	9	1/2	20
PLT732	7/32	9-1/2	1/2	20
PLT832	1/4	11	5/8	10
PLT932	9/32	11	5/8	10
PLT1032	5/16	11	5/8	10
PLT1232	3/8	11	3/4	5

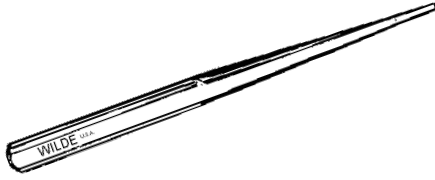

### INDUSTRIAL BLACK

PLT232B	1/16	7	3/8	20
PLT332B	3/32	7-1/2	3/8	20
PLT432B	1/8	8	3/8	20
PLT532B	5/32	8-1/2	1/2	20
PLT632B	3/16	9	1/2	20
PLT732B	7/32	9-1/2	1/2	20
PLT832B	1/4	11	5/8	10
PLT932B	9/32	11	5/8	10
PLT1032B	5/16	11	5/8	10
PLT1232B	3/8	11	3/4	5

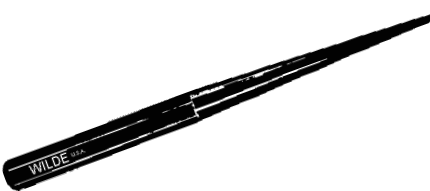

PLIERS  
PUNCHES, CHISELS & PRY BARS  
WRENCHES  
SCREWDRIVERS  
PLUMBING & INDUSTRIAL  
AUTOMOTIVE  
SERVICE TOOLS  
DISPLAYS

# PUNCHES

HEX STOCK

Cat. No.

Cut

Length Approx.

Stock Size

St. Pk.

## CENTER PUNCHES

### NATURAL FINISH



PC832		4-1/4	1/4	20
PC1032		4-1/2	5/16	20
PC1232		5	3/8	20
PC1432		5-1/2	7/16	20
PC1632		6	1/2	10
PC2032		7	5/8	10

### INDUSTRIAL BLACK

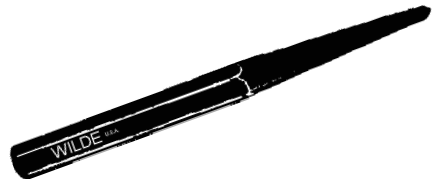

PC832B		4-1/4	1/4	20
PC1032B		4-1/2	5/16	20
PC1232B		5	3/8	20
PC1432B		5-1/2	7/16	20
PC1632B		6	1/2	10
PC2032B		7	5/8	10

## PRICK PUNCHES

### NATURAL FINISH

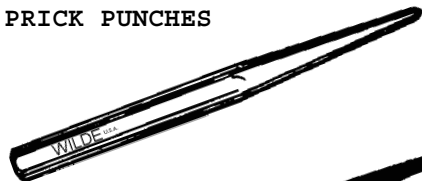

PR832		4-1/4	1/4	20
PR1032		4-1/2	5/16	20
PR1232		5	3/8	20
PR1632		6	1/2	10

### INDUSTRIAL BLACK

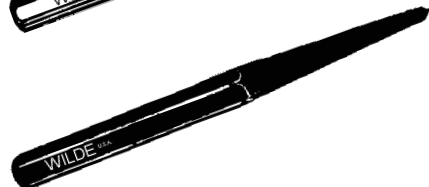

PR832B		4-1/4	1/4	20
PR1032B		4-1/2	5/16	20
PR1232B		5	3/8	20
PR1632B		6	1/2	10

## SOLID PUNCHES

### NATURAL FINISH

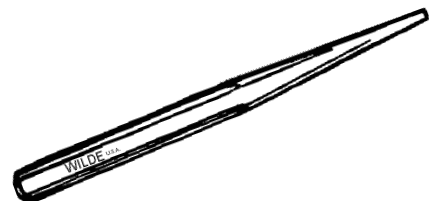

PS232	1/16	4-1/2	5/16	20
PS332	3/32	4-1/2	5/16	20
PS432	1/8	4-1/2	5/16	20
PS532	5/32	5	3/8	20
PS632	3/16	5	3/8	20
PS732	7/32	5-1/2	1/2	20
PS832	1/4	6	1/2	20
PS1032	5/16	7	5/8	10
PS1232	3/8	8	3/4	10

### INDUSTRIAL BLACK

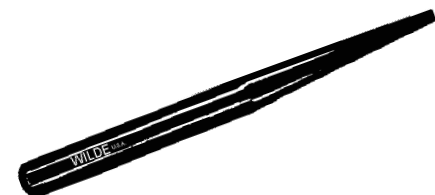

PS232B	1/16	4-1/2	5/16	20
PS332B	3/32	4-1/2	5/16	20
PS432B	1/8	4-1/2	5/16	20
PS532B	5/32	5	3/8	20
PS632B	3/16	5	3/8	20
PS732B	7/32	5-1/2	1/2	20
PS832B	1/4	6	1/2	20
PS1032B	5/16	7	5/8	10
PS1232B	3/8	8	3/4	10

## LINING UP BAR

### NATURAL FINISH



LB632	3/16	12	3/8	20
LB732	7/32	14	1/2	20
LB832	1/4	16	5/8	20
LB1032	5/16	18	3/4	5

### INDUSTRIAL BLACK



LB632B	3/16	12	3/8	20
LB732B	7/32	14	1/2	20
LB832B	1/4	16	5/8	20
LB1032B	5/16	18	3/4	5

PLIERS  
PUNCHES, CHISELS & PRY BARS  
WRENCHES  
SCREWDRIVERS  
PLUMBING & INDUSTRIAL  
AUTOMOTIVE  
SERVICE TOOLS  
DISPLAYS



PRY BARS	HEX STOCK	Cat. No.	Length Approx.	Stock Size	St. Pk.
----------	-----------	----------	----------------	------------	---------

JIMMY PRY BARS

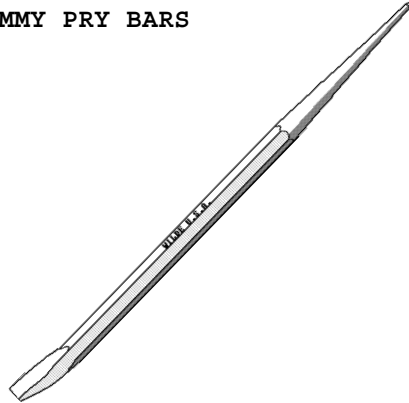

NATURAL FINISH	
JB1632	14 1/2 5
JB2032	16 5/8 5
JB2432	20 3/4 5
JB2432-24	24 3/4 5
JB2832	30 7/8 5
INDUSTRIAL BLACK	
JB1632B	14 1/2 5
JB2032B	16 5/8 5
JB2432B	20 3/4 5
JB2432-24B	24 3/4 5
JB2832	30 7/8 5

PLIERS

PUNCHES, CHISELS & PRY BARS

WRENCHES

SCREWDRIVERS

PRY BARS



NATURAL FINISH	
PB2032	18 5/8 1
PB2432	24 3/4 1
INDUSTRIAL BLACK	
PB2032B	18 5/8 1
PB2432B	24 3/4 1

PLUMBING & INDUSTRIAL

AUTOMOTIVE

ROLLING HEAD PRY BARS



NATURAL FINISH	
RH1232-9	9 3/8 5
RH1632-12	12 1/2 5
RH1632	15 1/2 5
RH2032	18 5/8 5
INDUSTRIAL BLACK	
RH1232-9B	9 3/8 5
RH1632-12B	12 1/2 5
RH1632B	15 1/2 5
RH2032B	18 5/8 5

SERVICE TOOLS

DISPLAYS

PRY BARS with HANDLE

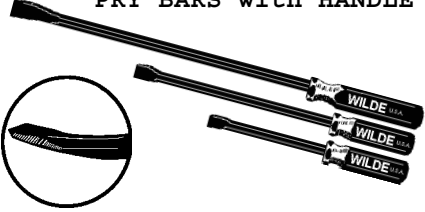

INDUSTRIAL BLACK					
	CUT	EXPOSED	OVERALL	STOCK	
HPB1232-7B	5/8	7	12	3/8	3
HPB1232-12B	5/8	12	17	3/8	3
HPB1632-18B	11/16	18	25	1/2	3
HPB1632-24B	11/16	24	31	1/2	3
HPB2032-28B	7/8	28	36	5/8	3

PRY BAR SET



HPB3B	3-Piece Pry Bar Set with Handle. Packaged in molded tray with clear lid. Set consists of 1 each:	1
HPB1232-7B	HPB1232-12B	HPB1632-18B

# PUNCH & CHISEL SETS - HEX STOCK



CC5

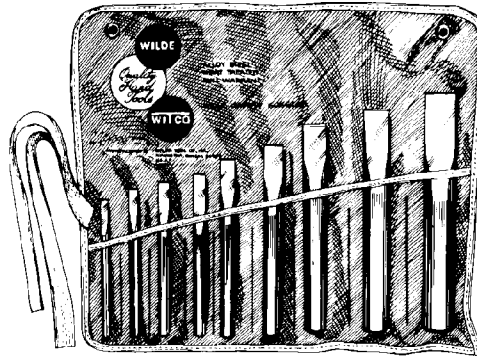

CC9



CCL4



PP5



PPL4



PLT5

Cat. No.	Description	St. Pk.
CC5	5-Piece Cold Chisel Set in a clear, sturdy, zipper seal hang-up vinyl pouch. Set consists of 1 each: CC1032 CC1232 CC1632 CC2032 CC2432	5
CC9	9-Piece Cold Chisel Set in a sturdy roll kit vinyl pouch. Set consists of 1 each: CC832 CC1032 CC1232 CC1432 CC1632 CC2032 CC2432 CC2832 CC3232	1
CCL4	4-Piece Long Cold Chisel Set in a clear, sturdy, zipper seal hang-up vinyl pouch. Set consists of 1 each: CCL2032 CCL2432 CCL2832 CCL3232	5
PP5	5-Piece Pin Punch Set in a clear, sturdy, zipper seal hang-up vinyl pouch. Set consists of 1 each: PP332 PP432 PP532 PP632 PP832	5
PPL4	4-Piece Long Pin Punch Set in a clear, sturdy, zipper seal hang-up vinyl pouch. Set consists of 1 each: PPL632 PPL832 PPL1032 PPL1232	5
PLT5	5-Piece Long Taper Punch Set in a clear, sturdy, zipper seal hang-up vinyl pouch. Set consists of 1 each: PLT432 PLT532 PLT632 PLT732 PLT832	5

PLIERS  
PUNCHES, CHISELS & PRY BARS  
WRENCHES  
SCREWDRIVERS  
PLUMBING & INDUSTRIAL  
AUTOMOTIVE  
SERVICE TOOLS  
DISPLAYS



# PUNCH & CHISEL SETS - HEX STOCK



G6



K5

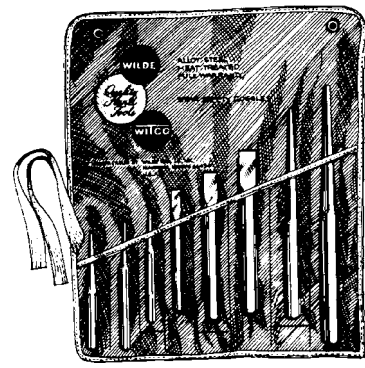

K8

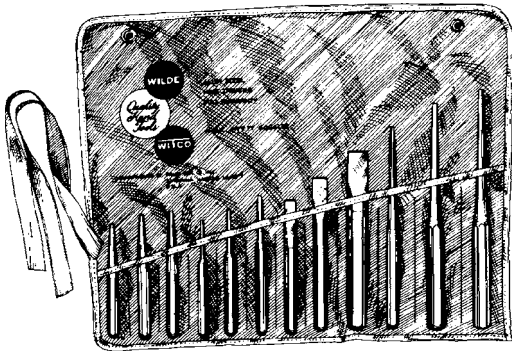

K12

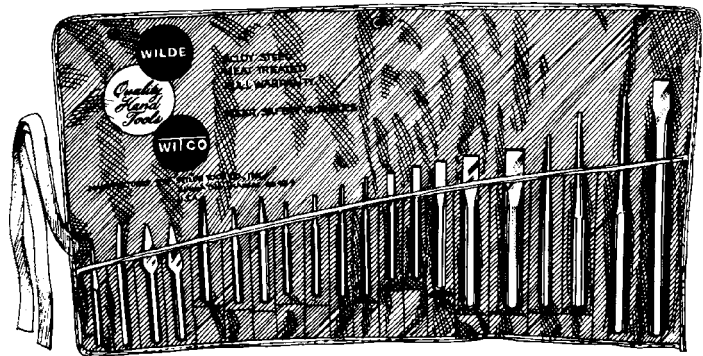

K20

Cat. No.	Description	St. Pk.
G6	6-Piece GUNSMITH Set in a clear, sturdy, zipper seal hang-up vinyl pouch. Set consists of 1 each: PC832 PP232 PP564 PP332 PP432 PS332	5
K5	5-Piece Punch & Chisel Set in a clear, sturdy, zipper seal hang-up vinyl pouch. Set consists of 1 each: CC1232 CC2032 PC1232 PP632 PS632	5
K8	8-Piece Punch & Chisel Set in a sturdy roll kit vinyl pouch. Set consists of 1 each: CC1232 CC2032 CC2432 PC1232 PP432 PP632 PLT632 PLT832	1
K12	12-Piece Punch & Chisel Set in a sturdy roll kit vinyl pouch. Set consists of 1 each: CC1232 CC1632 CC2432 PC1232 PP332 PP432 PP632 PLT432 PLT632 PLT732 PR1232 PS432	1
K20	20-Piece Master Mechanics Punch & Chisel Set in a sturdy roll kit vinyl pouch. Set consists of 1 each: CC1032 CC1232 CC1632 CC2432 CC2832 CCL2432 CD832 CP832 CR832 PC1232 PP332 PP432 PP532 PP632 PLT432 PLT632 PLT832 PR1232 PS332 PS632	1

PLIERS  
PUNCHES, CHISELS & PRY BARS  
WRENCHES  
SCREWDRIERS  
PLUMBING & INDUSTRIAL  
AUTOMOTIVE  
SERVICE TOOLS  
DISPLAYS

Each **WILDE®** Roll Spring Punch has a pilot point that fits into the hollow center of the pin, holding the driving shoulder of the punch in perfect contact position. Pins are quickly and easily removed without damage to wall of hole or pin.

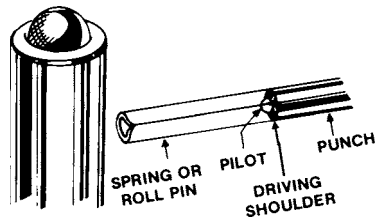

	Point Size	Pin Length	Overall Length	
RS232	1/16	1	2-3/4	10
RS564	5/64	1-1/2	3-1/4	10
RS332	3/32	1-1/2	3-1/2	10
RS432	1/8	2	4	10
RS532	5/32	2-1/2	4-1/2	10
RS632	3/16	2-1/2	4-1/2	10
RS732	7/32	3	5	10
RS832	1/4	3-1/2	5-1/2	10
RS1032	5/16	4	6	10
RS1232	3/8	4	6	10
RS1432	7/16	4	6	10
RS1632	1/2	4	6	10



RS906	6-Piece Roll Spring Punch Set in clear, zipper seal, hang-up vinyl pouch.	5	Set of 1 each: RS432 RS532 RS632 RS732 RS832 RS1032
-------	---	---	--

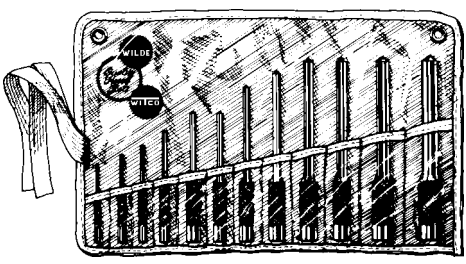

RS912	12-Piece Roll Spring Punch Set in a sturdy roll kit vinyl pouch.	5	Set of 1 each: RS232 RS564 RS332 RS432 RS532 RS632 RS732 RS832 RS1032 RS1232 RS1432 RS1632
-------	--	---	--

PLIERS  
 PUNCHES, CHISELS & PRY BARS  
 WRENCHES  
 SCREWDRIVERS  
 PLUMBING & INDUSTRIAL  
 AUTOMOTIVE  
 SERVICE TOOLS  
 DISPLAYS



# NOTES



# WRENCHES

## WILDE ADJUSTABLE WRENCHES

Drop-forged alloy steel. Properly heat treated with jaws accurately machined. Extra strong, extra thin jaws to get into tight places. All parts are subjected to the most modern scientific process of heat treating. Every handle uses a husky I-Beam construction and has a hole for hanging up the wrench. Wrenches are finished in either plated or industrial black finish. See Page 40.

## S.A.E. & METRIC

### WILDE COMBINATION WRENCHES

Quality combination wrenches, drop forged from alloy steel, precision heat treated, with polished heads and double plating of nickel and chrome. Box end for easy tightening of nuts, open end of the same size for fast turning. Box end is offset 15° to clear obstructions and the 15° open end needs only 30° of handle movement. All wrenches are 12 point. See Page 34. Sets Page 34.

### RATCHETING BOX WRENCHES

Ideal when working in limited space. Sturdy and thin, they reach into extremely close places. They are open faced and reversible by merely turning the wrench over. The 5/8" by 3/4" is practically a must for installing and removing oil filters on late model Ford, Mercury, Lincoln, Oldsmobile, Dodge cars. High grade alloy steel. Plated. Sizes to and including 9/16" are six point, larger sizes are twelve point.

Standard, Metric and Refrigeration sizes available. See Pages 36 & 37. Sets Page 36 & 37.

### WILDE IGNITION WRENCHES

Drop forged from special alloy steel. Thin, light weight but amazingly strong. Open end wrenches have a 15° angled head. Box end wrenches are 6 point with a 45° offset. See Page 35. Sets page 35.

## SOCKET WRENCHES

A full line of 1/4", 3/8" and 1/2" SAE and METRIC sockets and accessories. Sets are furnished in either heavy duty molded storage cases or metal boxes. See Pages 28, 29, 30, 31, 32 & 33.

## WILDE'S IMPROVED AIR CONDITIONING AND REFRIGERATION RATCHETS

For servicing automotive, commercial, and home air-conditioners, refrigerators and freezers. Heavy duty fully reversible. Wide size ranges. See Page 37.



## A NEW ANGLE ON AN ESTABLISHED HAND TOOL

To be precise, it's a 25° offset angle on our line of Ratcheting Box Wrenches. These new wrenches allow you to reach those tight situations without scraping your knuckles and still provides you the speed and convenience of a Ratcheting Box Wrench.

In addition, you can reverse directions by simply flipping the reversing lever with your thumb or finger.

Anytime you need a wrench, the work goes faster with a Ratcheting Box Wrench. See Pages 38 & 39. Sets Page 38 & 39..

## METRIC IGNITION WRENCHES

Open end wrenches which have 15° and 60° openings. All included in a 12-piece ignition set which includes guage and spark testing screwdriver. See Page 35. Set Page 35.

## SPARK TESTING SCREWDRIVER

5-1/4" Spark Testing Screwdriver. 1/8" x 2-1/2". Clear plastic handle with replaceable charge testing bulb. See Page 35.

PLIERS

PUNCHES, CHISELS & PRY BARS

WRENCHES

SCREWDRIVERS

PLUMBING & INDUSTRIAL

AUTOMOTIVE

SERVICE TOOLS

DISPLAYS



# SOCKET SETS

Cat. No.	Description	St. Pk.	Sets Consists of 1 each:
----------	-------------	---------	--------------------------

PLIERS

PUNCHES, CHISELS & PRY BARS

WRENCHES

SCREWDRIERS

PLUMBING & INDUSTRIAL

AUTOMOTIVE

SERVICE TOOLS

DISPLAYS

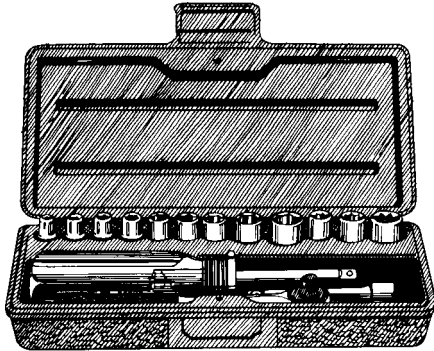

12000	15-Piece Socket Set. 1/4" Square Drive Standard. 9-6 Pt. Sockets: 3/16", 7/32", 1/4", 9/32", 5/16", 11/32", 3/8", 7/16", 1/2". 3-8 Pt. Sockets: 1/4", 5/16", 3/8". 1-Reversible Ratchet. 1-3" Extension. 1-Spinner Handle. In Molded Storage Case.	5	12103 12150 12180 12206 12207 12208 12209 12210 12211 12212 12214 12216 12908 12910 12912
-------	---	---	---

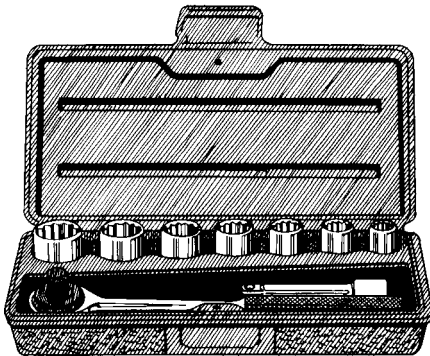

12001	9-Piece Socket Set. 3/8" Square Drive Standard. 7-12 Pt. Sockets: 3/8", 7/16", 1/2", 9/16", 5/8", 11/16", 3/4". 1-Reversible Ratchet. 1-3" Extension. In Metal Box.	5	13103 13150 13312 13314 13316 13318 13320 13322 13324
-------	--	---	---

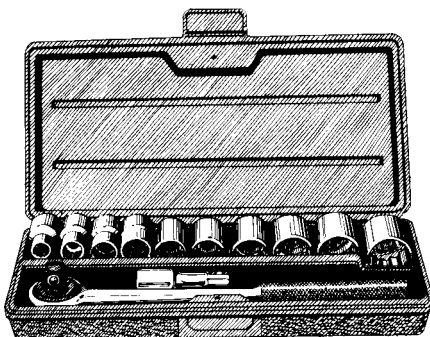

12003	12-Piece Socket Set. 1/2" Square Drive Standard. 10-12 Pt. Sockets: 3/8", 7/16", 1/2", 9/16", 5/8", 11/16", 3/4", 13/16", 7/8", 15/16". 1-Reversible Ratchet. 1- 2-1/2" Extension. In Molded Storage Case.	5	14102 14150 14312 14314 14316 14318 14320 14322 14324 14326 14328 14330
-------	--	---	--

# SOCKET SETS

Cat. No. Description St. Pk. Sets Consists of 1 each:

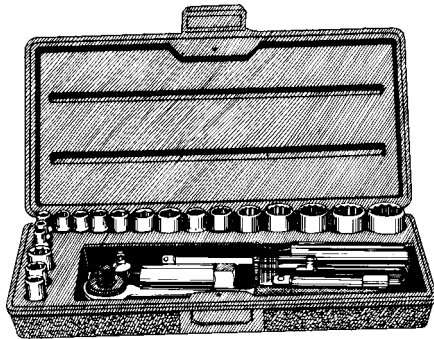

12004 24-Piece Standard Set. 5

1/4" & 3/8" Square Drive Standard.

1/4" = 9-6 Pt. Sockets:  
 3/16", 7/32", 1/4",  
 9/32", 5/16", 11/32",  
 3/8", 7/16", 1/2".

3-8 Pt. Sockets:  
 1/4", 5/16", 3/8".

1-Spinner Handle.

3/8"= 7-12 Pt. Sockets:  
 3/8", 7/16", 1/2",  
 9/16", 5/8", 11/16",  
 3/4".

1-Reversible Ratchet.  
 1-3" Extension.  
 1-3/8"F to 1/4"M Adaptor.  
 1-5/8" Spark Plug Socket.  
 In Metal Box.

12180  
 13103  
 13150  
 13181  
 12206  
 12207  
 12208  
 12209  
 12210  
 12211  
 12212  
 12214  
 12216  
 12908  
 12910  
 12912  
 13312  
 13314  
 13316  
 13318  
 13320  
 13322  
 13324  
 13620

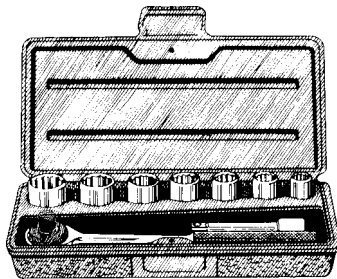

12002 9-Piece Socket Set. 5

3/8" Square Drive **Metric**.

7-12 Pt. Sockets:  
 10mm, 12mm, 13mm,  
 14mm, 15mm, 17mm,  
 19mm.

1-Reversible Ratchet.  
 1-3" Extension.  
 In Metal Box.

13103  
 13150  
 53310  
 53312  
 53313  
 53314  
 53315  
 53317  
 53319

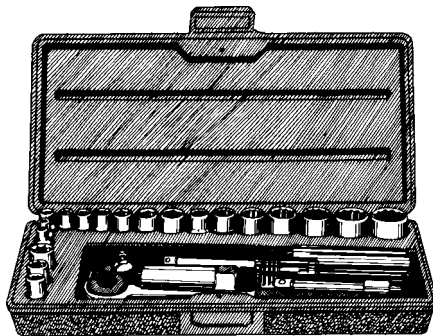

12005 24-Piece Socket Set. 5

1/4" & 3/8" Square Drive **Metric**.

1/4"= 9-6 Pt. Sockets:  
 4mm, 4.5mm, 5mm,  
 5.5mm, 6mm, 7mm,  
 8mm, 9mm, 10mm.

3-8 Pt. Sockets:  
 1/4", 5/16", 3/8".

1- Spinner Handle.

3/8"=7-12 Pt. Sockets:  
 10mm, 12mm, 13mm,  
 14mm, 15mm, 17mm,  
 19mm.

1-Reversible Ratchet.  
 1-3" Extension.  
 1-3/8"F to 1/4"M Adaptor.  
 1-5/8" Spark Plug Socket.  
 In Metal Box.

12180  
 13103  
 13150  
 13181  
 12908  
 12910  
 12912  
 13620  
 52204  
 52245  
 52205  
 52255  
 52206  
 52207  
 52208  
 52209  
 52210  
 53310  
 53312  
 53313  
 53314  
 53315  
 53317  
 53319

PLIERS

PUNCHES, CHISELS & PRY BARS

WRENCHES

SCREWDRIVERS

PLUMBING & INDUSTRIAL

AUTOMOTIVE

SERVICE TOOLS

DISPLAYS



# SOCKETS 1/4" DRIVE

PLIERS  
PUNCHES, CHISELS & PRY BARS  
WRENCHES  
SCREWDRIVERS  
PLUMBING & INDUSTRIAL  
AUTOMOTIVE  
SERVICE TOOLS  
DISPLAYS

	Cat. No.	Description	St. Pk.
	12102	2" Extension	10
	12103	3" Extension	10
	12106	6" Extension	10
	903121	3-Pc. Set of #'s 12102-12106	5
	12150	5-1/2" Reversible Ratchet	10
	12606	5-1/2" Flex Handle	10
	12180	Spinner Handle	5
	12170	Universal Joint	10

Cat. No.	Size	St. Pk.	Cat. No.	Size	St. Pk.
----------	------	---------	----------	------	---------

## 6 POINT REGULAR SOCKETS

	12206	3/16"	10	12211	11/32"	10
	12207	7/32"	10	12212	3/8"	10
	12208	1/4"	10	12214	7/16"	10
	12209	9/32"	10	12216	1/2"	10
	12210	5/16"	10			
	909122	9-Piece Set of #'s 12206-12216				10

## 6 POINT DEEP SOCKETS

	12406	3/16"	10	12411	11/32"	10
	12407	7/32"	10	12412	3/8"	10
	12408	1/4"	10	12414	7/16"	10
	12409	9/32"	10	12416	1/2"	10
	12410	5/16"	10			
	909124	9-Piece Set of #'s 12406-12416				10

## 6 POINT REGULAR SOCKETS - METRIC

	52204	4mm	10	52207	7mm	10
	52245	4.5mm	10	52208	8mm	10
	52205	5mm	10	52209	9mm	10
	52255	5.5mm	10	52210	10mm	10
	52206	6mm	10			
	909522	9-Piece Set of #'s 52204-52210				10

## 8 POINT SOCKETS

	12908	1/4"	10			
	12910	5/16"	10			
	12912	3/8"	10			
	903129	3-Piece Set of #'s 12908-12912				10

# SOCKETS 3/8" DRIVE

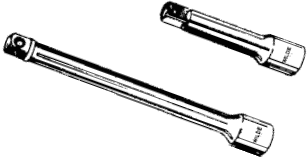
	Cat. No.	Description	St. Pk.
	13103	3" Extension	10
	13104	5" Extension	10
	13106	6" Extension	10
	13107	10" Extension	10
	904131	4-Pc. Set of #'s 13103-13107	5

PLIERS

	13150	8" Reversible Ratchet	10
---	-------	-----------------------	----

PUNCHES, CHISELS & PRY BARS

	13160	8" Flex Handle	10
---	-------	----------------	----

WRENCHES

	13170	Universal Joint	10
---	-------	-----------------	----

	13181	3/8"F x 1/4"M Adaptor	10
	13182	3/8"F x 1/2"M Adaptor	10
	902131	2-Pc. Set of #'s 13181-13182	5

SCREWDRIVERS

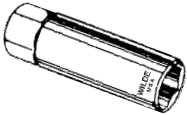
	13620	5/8" Spark Plug Socket	10
	13626	13/16" Spark Plug Socket	10
	902136	2-Pc. Set of #'s 13620-13626	5

PLUMBING & INDUSTRIAL

	Cat. No.	Size	St. Pk.	Cat. No.	Size	St. Pk.
<b>6 POINT REGULAR SOCKETS</b>						
	13212	3/8"	10	13220	5/8"	10
	13214	7/16"	10	13222	11/16"	10
	13216	1/2"	10	13224	3/4"	10
	13218	9/16"	10	13226	13/16"	10
	908132	8-Piece Set of #'s 13212-13226				5

AUTOMOTIVE

<b>12 POINT REGULAR SOCKETS</b>						
	13312	3/8"	10	13322	11/16"	10
	13314	7/16"	10	13324	3/4"	10
	13316	1/2"	10	13326	13/16"	10
	13318	9/16"	10	13328	7/8"	10
	13320	5/8"	10			
	911133	9-Piece Set of #'s 13312-13328				5

SERVICE TOOLS

DISPLAYS

3/8" Drive continued next page



# SOCKETS 3/8" DRIVE

Cat. No.	Size	St. Pk.	Cat. No.	Size	St. Pk.
----------	------	---------	----------	------	---------



## 12 POINT FLEX SOCKETS

TO BE DISCONTINUED  
WHEN STOCK  
DEPLETED

13312X	3/8"	10	13320X	5/8"	10
13314X	7/16"	10	13322X	11/16"	10
13316X	1/2"	10	13324X	3/4"	10
13318X	9/16"	10			

907133X 7-Piece Set of #'s 13312X-13324X 5



## 6 POINT DEEP SOCKETS

13412	3/8"	10	13422	11/16"	10
13414	7/16"	10	13424	3/4"	10
13416	1/2"	10	13426	13/16"	10
13418	9/16"	10	13428	7/8"	10
13420	5/8"	10			

909134 9-Piece Set of #'s 13412-13428 5



## 12 POINT DEEP SOCKETS

13512	3/8"	10	13522	11/16"	10
13514	7/16"	10	13524	3/4"	10
13516	1/2"	10	13526	13/16"	10
13518	9/16"	10	13528	7/8"	10
13520	5/8"	10			

909135 9-Piece Set of #'s 13512-13528 5



## 6 POINT REGULAR SOCKETS - METRIC

53207	7mm	10	53214	14 mm	10
53208	8mm	10	53215	15 mm	10
53209	9mm	10	53216	16 mm	10
53210	10 mm	10	53217	17 mm	10
53211	11 mm	10	53218	18 mm	10
53212	12 mm	10	53219	19 mm	10
53213	13 mm	10			

913532 13-Piece Set of #'s 53207-53219







## 12 POINT REGULAR SOCKETS - METRIC

53307	7mm	10	53314	14 mm	10
53308	8mm	10	53315	15 mm	10
53309	9mm	10	53316	16 mm	10
53310	10 mm	10	53317	17 mm	10
53311	11 mm	10	53318	18 mm	10
53312	12 mm	10	53319	19 mm	10
53313	13 mm	10			

913533 13-Piece Set of #'s 53307-53319 5

PLIERS  
PUNCHES, CHISELS & PRY BARS  
WRENCHES  
SCREWDRIERS  
PLUMBING & INDUSTRIAL  
AUTOMOTIVE  
SERVICE TOOLS  
DISPLAYS

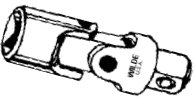
# SOCKETS 1/2" DRIVE

	Cat. No.	Description	St. Pk.			
	14102	2-1/2" Extension	10			
	14105	5" Extension	10			
	14110	10" Extension	5			
	903141	3-Pc. Set of #'s 14102-14110	5			
<hr/>						
	14150	10" Reversible Ratchet	5			
<hr/>						
	14160	10" Flex Handle	5			
	14161	17" Flex Handle	5			
	902141	2-Pc. Set of #'s 14160-14161	5			
<hr/>						
	14170	Universal Joint	10			
<hr/>						
	14181	1/2"F x 3/8"M Adaptor	10			
<hr/>						
	Cat. No.	Size	St. Pk.	Cat. No.	Size	St. Pk.

## 12 POINT REGULAR SOCKETS

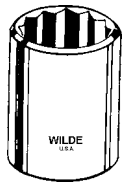
	14312	3/8"	10	14328	7/8"	10
	14314	7/16"	10	14330	15/16"	10
	14316	1/2"	10	14332	1"	10
	14318	9/16"	10	14334	1-1/16"	10
	14320	5/8"	10	14336	1-1/8"	10
	14322	11/16"	10	14338	1-3/16"	10
	14324	3/4"	10	14340	1-1/4"	10
	14326	13/16"	10			
	915143	15-Piece Set of #'s 14312-14340				1

PLIERS

PUNCHES, CHISELS & PRY BARS

WRENCHES

SCREWDRIVERS

PLUMBING & INDUSTRIAL

AUTOMOTIVE

SERVICE TOOLS

DISPLAYS



**FRACTIONAL & METRIC  
COMBINATION WRENCHES**

Cat. No.	Description	OAL	St. Pk.
189	3/8" Combination Wrench.	4-7/8"	20
190	7/16" Combination Wrench.	5-1/2"	20
191	1/2" Combination Wrench.	6"	10
192	9/16" Combination Wrench.	6-7/8"	10
193	5/8" Combination Wrench.	7-1/2"	10
194	11/16" Combination Wrench.	8-5/16"	10
195	3/4" Combination Wrench.	9-1/4"	10
196	13/16" Combination Wrench.	10-1/4"	10
197	7/8" Combination Wrench.	11-1/4"	10
198	15/16" Combination Wrench.	12-3/8"	10
199	1" Combination Wrench.	13-1/2"	10
201	1-1/16" Combination Wrench.	14-3/4"	5
202	1-1/8" Combination Wrench.	15-3/4"	5
203	1-1/4" Combination Wrench.	17-1/2"	5
MC10	10mm Combination Wrench.	4-3/8"	10
MC11	11mm Combination Wrench.	5-1/2"	10
MC12	12mm Combination Wrench.	5-3/4"	10
MC13	13mm Combination Wrench.	6"	10
MC14	14mm Combination Wrench.	6-7/8"	10
MC15	15mm Combination Wrench.	7-1/4"	10
MC16	16mm Combination Wrench.	7-1/2"	10
MC17	17mm Combination Wrench.	8-1/4"	10
MC18	18mm Combination Wrench.	9"	10
MC19	19mm Combination Wrench.	9-1/4"	10

- 12 POINT BOX ENDS
- PRECISION BROACHED
- CHAMFERED BOX ENDS
- FULL POLISHED SIDES & FACES OF OPEN ENDS
- PLATED FOR DURABILITY

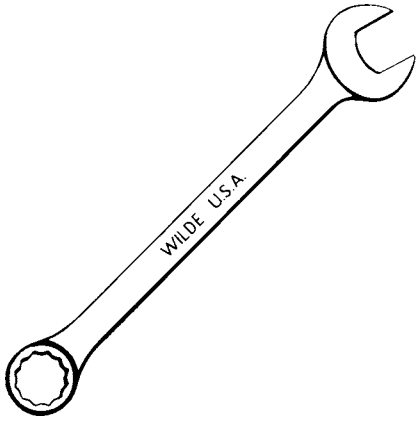

PLIERS  
PUNCHES, CHISELS & PRY BARS  
WRENCHES  
SCREWDRIERS  
PLUMBING & INDUSTRIAL  
AUTOMOTIVE  
SERVICE TOOLS  
DISPLAYS

208	6-Pc. Fractional Combination Wrench Set. 1 ea. 190-195 in roll kit.	1
208B	#208 in a box instead of roll kit.	1

208  
SMC6

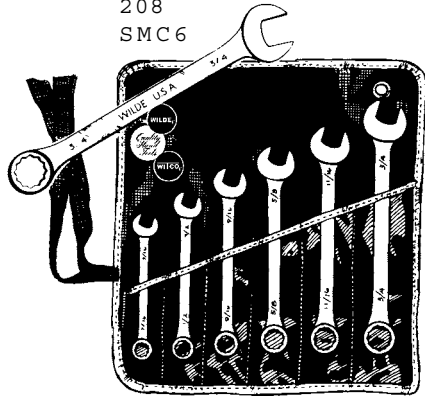

209	10-Pc. Fractional Combination Wrench Set. 1 ea. 189-195 & 197-199 in roll kit.	1
209B	#209 in a box instead of roll kit.	1

210	14-Pc. Fractional Combination Wrench Set. 1 ea. 189-203 in roll kit.	1
210B	#210 in a box instead of roll kit.	1

- 12 POINT BOX ENDS
- PRECISION BROACHED
- CHAMFERED BOX ENDS

SMC6	6-Pc. Metric Combination Wrench Set. 1 ea. MC10-MC15 in roll kit.	1
SMC6B	#SMC6 in a box instead of roll kit.	1

- FULL POLISHED SIDES & FACES OF OPEN ENDS
- PLATED FOR DURABILITY

SMC10	10-Pc. Metric Combination Wrench Set. 1 ea. MC10-MC19 in roll kit.	1
SMC10B	#SMC10 in a box instead of roll kit.	1

209  
SMC10

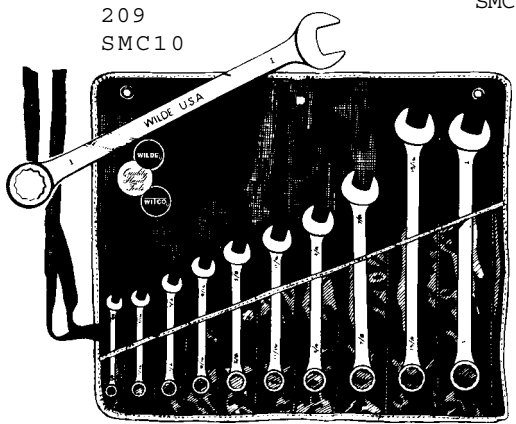

210

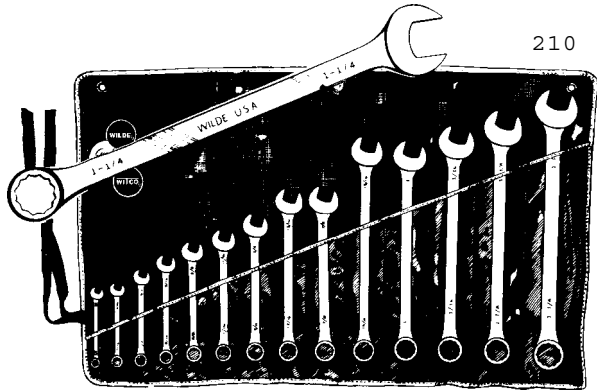



# IGNITION WRENCHES

	Cat. No.	Box Sizes	Length	Std. Pk.
	204	3/16"x13/64"	2-13/16"	20
	205	7/32"x15/64"	3-3/32"	20
	206	1/4"x9/32"	3-3/8"	20
	205	5/16"x11/32"	3-3/4"	20

		Sizes	Length	Thickness	Std. Pk.
	1718	13/64"x7/32"	3"	7/64"	20
	1719	15/64"x1/4"	3-1/4"	7/64"	20
	1720	9/32"x11/32"	3-1/2"	1/8"	20
	1721	5/16"x3/8"	3-3/4"	9/64"	20

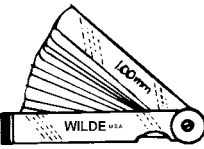
		Openings		Length	Head Thickness	Std. Pk.
		15°	60°			
	1722	6mm	5mm	3.00"	.125	20
	1723	7mm	8mm	3.315"	.156	20
	1724	8mm	7mm	3.315"	.156	20
	1725	10mm	9mm	3.565"	.156	20
	1726	9mm	10mm	3.565"	.156	20
	1727	11mm	12mm	4.128"	.188	20
	1728	12mm	11mm	4.128"	.188	20

	499	Metric Ignition Gauge. Contains thirteen 1/2" x 3" blades of the following thickness: .050, .100, .150, .200, .250, .300, .400, .500, .600, .700, .800, .900, 1.000mm's.	5
---	-----	--	---

	21900	5-1/4" Spark Testing Screw driver. 1/8" x 2-1/2". Clear plastic handle with replaceable charge testing bulb.	10
---	-------	--	----

Cat. No.	Description	Std. Pk.
156R	4-pc Ignition Wrench Set. Contains one each 1718, 1719, 1720, 1721 in plastic kit.	5
158R	5-pc. Ignition Set. Contains one each 1718, 1719, 1720, 1721, 5S in plastic kit.	5
159R	4-pc. Min. Box Wrench Set. Contains one each 204, 205, 206, 207 in plastic kit.	5
160R	8-pc. Ignition Wrench Set. Contains one each 1718, 1719, 1720, 1721, 204, 205, 206, 207 in plastic kit.	5
164R	7-pc. Ignition Set. Contains one each 1718, 1719, 1720, 1721, 5S, 504, 770 in plastic kit.	5
8954	12-pc. Ignition Set. Contains one each 1722-1728, 5S, 499, 21900, 175, 770 in plastic kit.	1

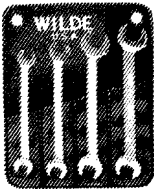

156R



158R

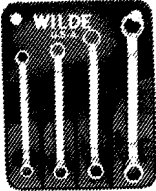

159R

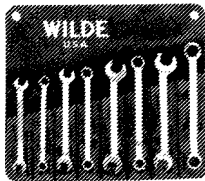

160R

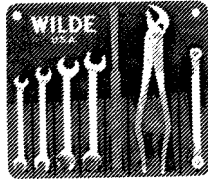

164R

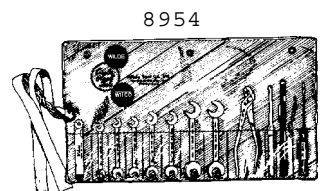

8954



PLIERS

PUNCHES, CHISELS & PRY BARS

WRENCHES

SCREWDRIVERS

PLUMBING & INDUSTRIAL

AUTOMOTIVE

SERVICE TOOLS

DISPLAYS

# RATCHETING WRENCHES

Cat.  
No.

Description

Std.  
Pk.

## RATCHET BOX WRENCH

- PLIERS
- PUNCHES, CHISELS & PRY BARS
- WRENCHES
- SCREWDRIERS
- PLUMBING & INDUSTRIAL
- AUTOMOTIVE
- SERVICE TOOLS
- DISPLAYS

**Box Sizes    Point    Length Thickness**



873	1/4" x 5/16"	6	4-1/8"	3/8"	6
874	3/8" x 7/16"	6	5-1/2"	3/8"	6
875B	1/2" x 7/16"	6	6-3/4"	1/2"	6
875	1/2" x 9/16"	6	6-3/4"	1/2"	6
876	5/8" x 11/16"	12	8"	1/2"	6
877	5/8" x 3/4"	12	8"	1/2"	6
878	11/16" x 13/16"	12	9-1/4"	1/2"	6
879	3/4" x 7/8"	12	9-1/4"	1/2"	6
880	13/16" x 15/16"	12	9-1/4"	1/2"	6

NOTE:  
#873 IS NOT FOR USE ON  
BATTERY TERMINAL NUTS.  
SEE #871 PAGES 37.

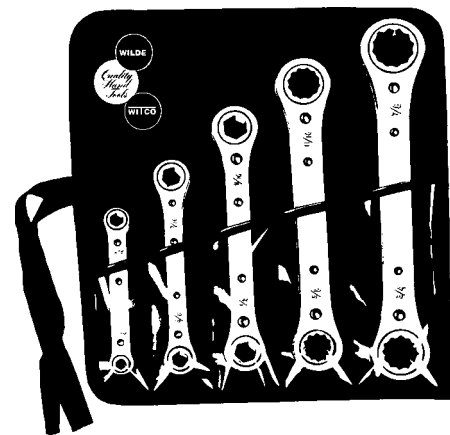

883	3-Pc. Ratchet Box Wrench Set. Contains one each 874, 875 and 876 in a handy plastic kit.	5
885	5-Pc. Ratchet Box Wrench Set. Contains one each 873, 874, 875, 876 and 879 in a handy plastic kit.	5

# RATCHETING WRENCHES

Cat. No.	Description	Std. Pk.
----------	-------------	----------

## METRIC RATCHET BOX WRENCH

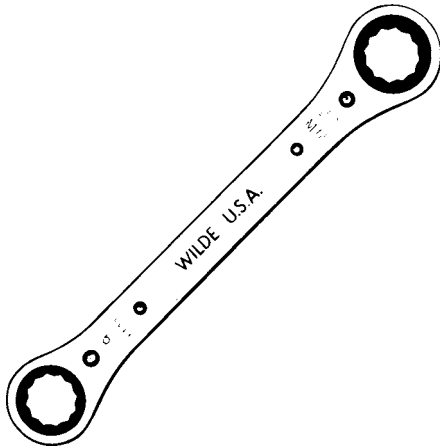

Cat. No.	Box Sizes	Point	Length	Std. Pk.
862	7mm x 8mm	6	4-1/4"	6
863	9mm x 10mm	6	5-1/2"	6
864	11mm x 12mm	6	6-7/8"	6
865	13mm x 14mm	6	6-7/8"	6
866	15mm x 17mm	12	8"	6
867	16mm x 18mm	12	8"	6
868	19mm x 21mm	12	9-1/4"	6

PLIERS  
PUNCHES, CHISELS & PRY BARS  
WRENCHES

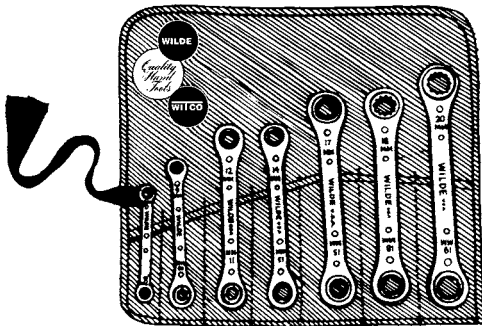

870	7-Pc. Metric Ratchet Box Wrench Set. Contains one each 862, 863, 864, 865, 866, 867 and 868 in a plastic kit.	5
-----	--	---

SCREWDRIVERS  
PLUMBING & INDUSTRIAL

## Air Conditioning & Refrigeration RATCHETS

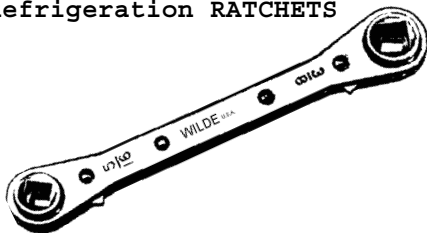

900	3/8" x 5/16" Square 1/4" x 3/16" Square	6
990	1/4" x 3/16" Square 9/16 x 1/2" Hex	6

AUTOMOTIVE  
SERVICE TOOLS

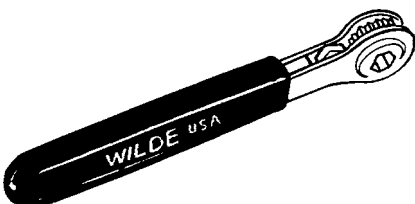

871	5/16" Reversible Side Terminal Battery Wrench. Insulated vinyl handle prevents electrical shock. Heat-treated and nickel-chrome plated.	6
-----	---	---

DISPLAYS



RATCHET BOX WRENCH



PLIERS  
PUNCHES, CHISELS & PRY BARS  
WRENCHES  
SCREWDRIVERS  
PLUMBING & INDUSTRIAL  
AUTOMOTIVE  
SERVICE TOOLS  
DISPLAYS

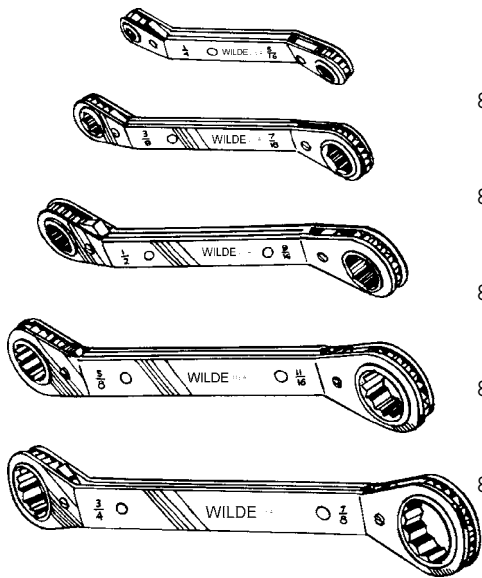

	Box Sizes	Point	Length	
800	1/4" x 5/16"	12	4-3/32"	6
801	3/8" x 7/16"	12	5-7/32"	6
802	1/2" x 9/16"	12	6-15/32"	6
803	5/8" x 11/16"	12	7-21/32"	6
804	3/4" x 7/8"	12	8-3/4"	6

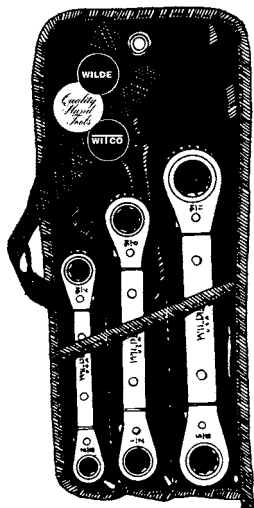

805 3-Pc. OFF/SET Ratchet Box Wrench Set. Contains one each 801, 802 and 803 in a handy plastic kit. 5

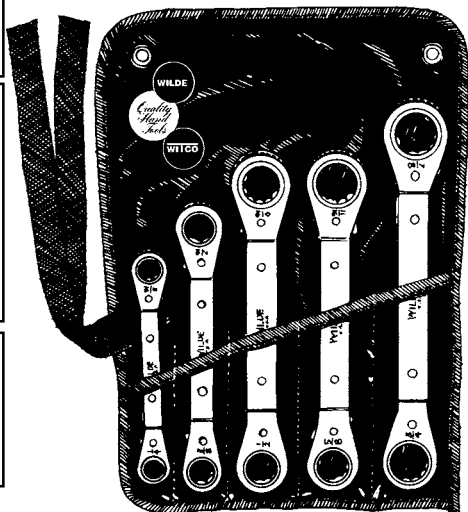

806 5-Pc. OFF/SET Ratchet Box Wrench Set. Contains one each 800, 801, 802, 803 and 804 in a handy plastic kit. 5

**METRIC RATCHET BOX WRENCH**



**Box Sizes      Point      Length**

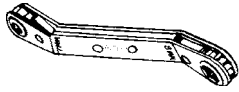

810      7mm x 8mm      6      4-3/32"      6



811      9mm x 10mm      6      5-7/32"      6

812      11mm x 12mm      6      6-15/32"      6

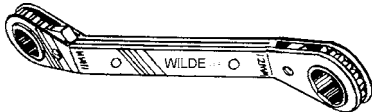

813      13mm x 14mm      6      6-15/32"      6

814      15mm x 17mm      12      7-27/32"      6

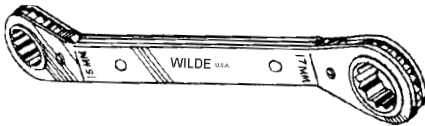

815      16mm x 18mm      12      7-27/32"      6

816      19mm x 21mm      12      8-3/4"      6

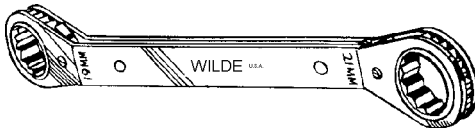

PLIERS  
PUNCHES, CHISELS & PRY BARS  
WRENCHES  
SCREWDRIVERS  
PLUMBING & INDUSTRIAL  
AUTOMOTIVE  
SERVICE TOOLS  
DISPLAYS

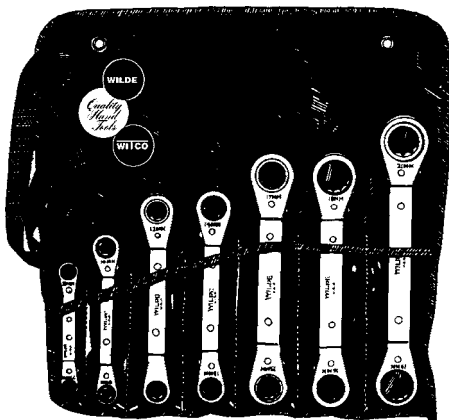

817      7-Pc. OFF/SET Ratchet Box Wrench Set. Contains one each 810, 811, 812, 813, 814, 815 and 816 in a handy plastic kit.      5



**PLATED**

Length Jaw Capacity

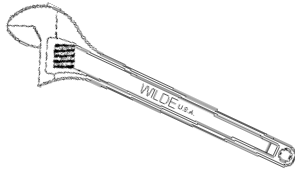

AWC 4 4" 1/2" 5

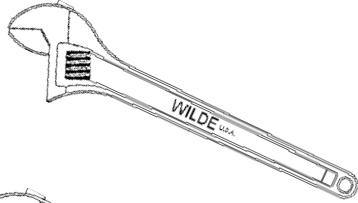

AWC 6 6" 15/16" 5

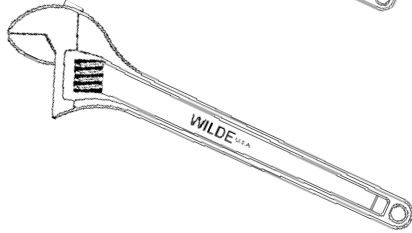

AWC 8 8" 1-1/8" 5



AWC 10 10" 1-9/32" 5



AWC 12 12" 1-1/2" 5



AWC 15 15" 1-3/4" 5

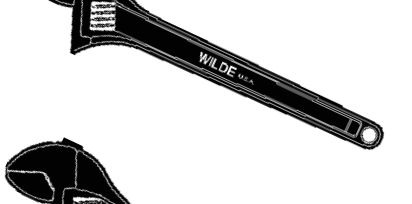

AWC 18 18" 2-1/8" 1



AWC 24 24" 2-1/2" 1

- Forged Alloy Steel
- Heat Treated for Strength
- Spring Tension Knurl for smoother operation
- Precision Pin prevents loosening of lower jaw
- Rounded Edges for comfort and better grip
- Tapered Head & Flat Nose for access into tight places

**INDUSTRIAL BLACK**

AWB 4 4" 1/2" 5



AWB 6 6" 15/16" 5



AWB 8 8" 1-1/8" 5



AWB 10 10" 1-9/32" 5



AWB 12 12" 1-1/2" 5



AWB 15 15" 1-3/4" 5



AWB 18 18" 2-1/8" 1



AWB 24 24" 2-1/2" 1

PLIERS  
PUNCHES, CHISELS & PRY BARS  
WRENCHES  
SCREWDRIERS  
PLUMBING & INDUSTRIAL  
AUTOMOTIVE  
SERVICE TOOLS  
DISPLAYS



# SCREWDRIVERS

## WILDE "INSULITE" SQUARE SHANK SCREWDRIVERS

Handles are turned of extruded, clear white, acetate plastic rod, ferrule dipped red. They are non-inflammable; shockproof, breakproof and impervious to grease. Comfortable fluted design, extra large diameter and length give you a handful of screwdriver for a high power non-slip grip. Will not roll when laid down. Bits, of alloy steel, are heat treated for maximum hardness, toughness and wear. They are forged with extra long tapers to hold in screw slots under pressure without backing out. Bits are satin finish and plated.  
**See Page 42.**

## WILDE PHILLIPS ROUND SHANK SCREWDRIVERS SUPER HARD BITS

The general use of case hardened self tapping screws requires a Phillips bit that will fit accurately and stand up and give real service on these screws. Bits on these Screwdrivers are made of super hard alloy steel and accurately milled to size. Plated. Handles are "Insulite" fluted plastic non-flammable and wear resistant. They are of ample size for maximum comfort and turning power.  
**See Page 42.**

## 4 IN 1 SCREWDRIVER MINIATURE and STANDARD SIZE

Quick Change Screwdriver. Has two slotted ends and two Phillips ends. Comfortable fluted handle. Alloy steel.  
**PLUS TORX ® bits.**  
**See Page 43.**

## **NEW** WOODEN HANDLE SCREWDRIVERS

Back by popular demand. All the popular slotted and phillips sizes.  
**See Page 43.**

## STANDARD AND METRIC NUT DRIVERS

Sockets are machined from top grade tool steel, heat treated for extra hardness. All hollow shafts from the socket to the handle accommodate the longest stud. Shafts are machined from chrome vanadium steel, precision tempered and plated finished.  
**See Page 44.**

## TORX ® SCREWDRIVERS

General Motors, Ford and other major automotive manufacturers are now using TORX ® drive fasteners in seat belt and door striker bolts, door latches, deck lids, headlight bezels, carburetors, ignition systems and other applications.

Wilde Tool offers a complete line of TORX ® drivers for this new market.  
**See Page 45.**

## SLOTTED AND PHILLIPS SCREW STARTERS

This tool holds screws with a grip that will withstand an eight pound pull and automatically releases when pressure becomes too great. Lightweight Aluminum handles, tough high carbon steel gripping bits. This tool is made for starting screws only, use standard driver to tighten. Also available with magnet end and pencil clip.  
**See Page 45.**

## SCREWDRIVER SETS

Four of the most popular sets used. Three plastic handle sets and one **NEW WOODEN HANDLE** set.  
**See Page 43.**



PLIERS

PUNCHES, CHISELS  
& PRY BARS

WRENCHES

SCREWDRIVERS

PLUMBING &  
INDUSTRIAL

AUTOMOTIVE

SERVICE TOOLS

DISPLAYS



# SCREWDRIVERS

Cat. No. Description

Std. Pk.

## SLOTTED: SQUARE SHANK

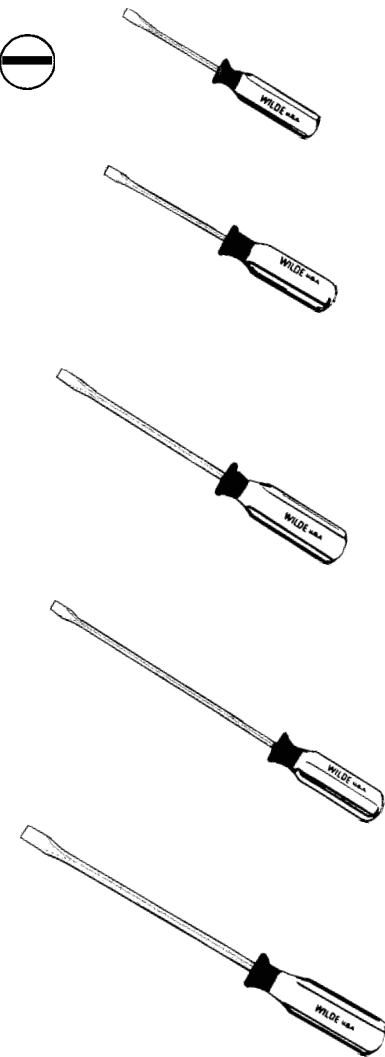

	Exposed Length	Handle Size	Overall Length		
S14	1/4" x 1-1/4"	1-3/16" x 2"	3-1/4"	10	Stubby
S22	1/8" x 2"	5/8" x 2-1/2"	4-1/2"	10	
S25	5/16" x 1-3/4"	1-1/4" x 4-1/2"	6-1/4"	10	
S42	1/8" x 4"	3/4" x 2-1/2"	6-1/2"	10	
S43	3/16" x 3-1/2"	1-1/16" x 3-3/4"	7-1/4"	10	
S44	1/4" x 4"	1-3/16" x 4-1/4"	8-1/4"	10	
S46	3/8" x 5"	1-5/16" x 4-3/4"	9-3/4"	10	
S64	1/4" x 6"	1-3/16" x 4-1/4"	10-1/4"	10	
S83	3/16" x 8"	1-1/16" x 3-3/4"	11-3/4"	10	
S85	5/16" x 7-1/2"	1-1/4" x 4-1/2"	12"	10	
S86	3/8" x 9"	1-5/16" x 4-3/4"	13-3/4"	10	
S104	1/4" x 12"	1-3/16" x 4-1/4"	16-1/4"	5	
S126	3/8" x 12"	1-5/16" x 4-3/4"	16-3/4"	5	

## PHILLIPS: ROUND SHANK

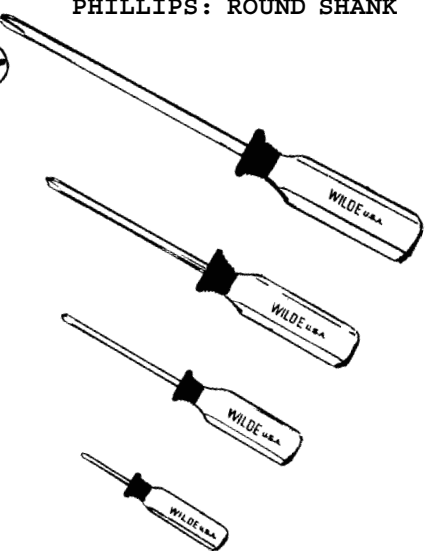

	Exposed Length	Point No.	Handle Size	Overall Length	Screw Size		
P142	1/4" x 1-1/2"	2	1-3/16"x2"	3-1/2"	5-10	10	Stubby
P220	1/8" x 2-1/2"	0	5/8"x2-1/2"	5"	2 & >2	10	
P331	3/16" x 3"	1	7/8" x 3"	6"	2-5	10	
P442	1/4" x 4"	2	1-1-16"x3-3/4"	7-3/4"	5-10	10	
P653	5/16" x 6-1/4"	3	1-3/16"x4-1/4"	10-1/2"	10-16	10	

PLIERS  
PUNCHES, CHISELS & PRY BARS  
WRENCHES  
SCREWDRIVERS  
PLUMBING & INDUSTRIAL  
AUTOMOTIVE  
SERVICE TOOLS  
DISPLAYS

# SCREWDRIVER SETS

Cat. No. Description Std. Pk.

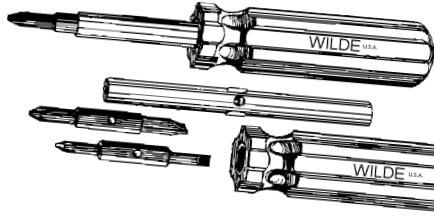

SW2 **MINIATURE** 4 in 1 Quick Change Screwdriver. Contains 1/8" and 3/16" Slotted; #0 and #1 Phillips. Alloy Steel. Overall Length 5-1/4".

SW2-1S Bit Only for SW2. 1/8" and 3/16". 10  
 SW2-2L Bit Only for SW2. #0 and #1. 10

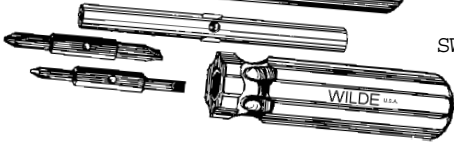

SW4 4 in 1 Quick Change Screwdriver. Bits reverse. Contains 3/16" and 5/16" Slotted; #1 and #2 Phillips. Alloy Steel. Overall Length 7-1/2".

SW4-1S Bit only for SW4. 3/16" and 5/16". 10  
 SW4-2L Bit only for SW4. #1 and #2. 10  
 SW4-T15 Bit only. Torx ® T15 and T20. 10  
 SW4-T25 Bit only. Torx ® T25 and T30. 10  
 SW4-R Bit only. Robinson. Reversible. 10

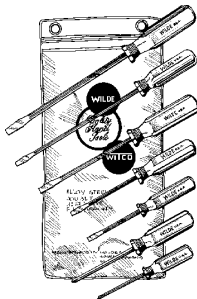

SW8 7-Pc. Plastic Handle Screwdriver Set. 5 Flat Blades & 2 Phillips. Contains one each **S43, S44, S64, S83, S85, P331** and **P442**. Packed in clear, sturdy hang-up vinyl pouch. 1

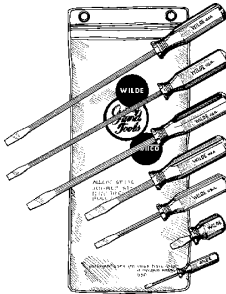

SW9 7-Pc. Plastic Handle Screwdriver Set. Contains one each **S14, S22, S44, S46, S64, S85, and S86**. Packed in clear, sturdy hang-up vinyl pouch. 1

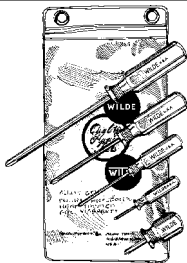

SW10 5-Pc. Plastic Handle Phillips Screwdriver Set. Contains one each **P142, P220, P331, P442** and **P653**. Packed in clear, sturdy hang-up vinyl pouch. 1

**NEW**



SW7 7-Pc. Wooden Handle Screwdriver Set. Packed in clear, sturdy hang-up vinyl pouch as follows. 1

SW7-1 3/16" x 2-1/2" #1 Phillips 10  
 SW7-2 1/4" x 3" #2 Phillips 10  
 SW7-3 1/8" x 3" Slotted 10  
 SW7-4 3/16" x 2-1/2" Slotted 10  
 SW7-5 3/16" x 5" Slotted 10  
 SW7-6 1/4" x 6" Slotted 10  
 SW7-7 5/16" x 7-1/2" Slotted 5

PLIERS  
 PUNCHES, CHISELS & PRY BARS  
 WRENCHES  
 SCREWDRIVERS  
 PLUMBING & INDUSTRIAL  
 AUTOMOTIVE  
 SERVICE TOOLS  
 DISPLAYS



**FRACTIONAL & METRIC NUT DRIVERS**

Cat. No. Description

Std. Pk.

**HEX FRACTIONAL NUT DRIVERS**

PLIERS  
PUNCHES, CHISELS & PRY BARS  
WRENCHES  
SCREWDRIVERS  
PLUMBING & INDUSTRIAL  
AUTOMOTIVE  
SERVICE TOOLS  
DISPLAYS

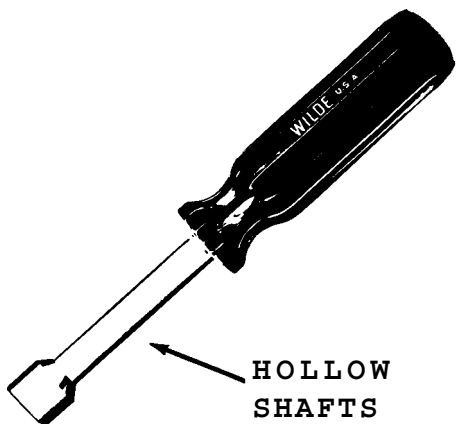

Size	Overall Length	Handle Color	
3/16"	6-5/8"	Black	10
1/4"	6-5/8"	Red	10
5/16"	6-5/8"	Amber	10
11/32"	6-5/8"	Green	10
3/8"	6-5/8"	Blue	10
7/16"	7"	Brown	10
1/2"	7"	Red	10

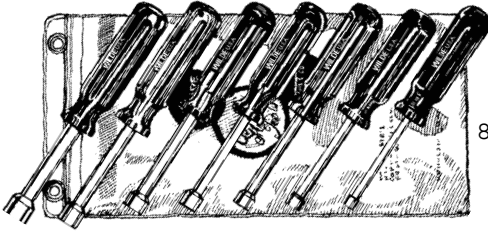

88	7-Pc. Nut Driver Set. Contains one each 81-87 in a vinyl pouch.	10
----	---	----

**HEX METRIC NUT DRIVERS**



MD 4	4 mm	6-5/8"	Black	10
MD4 5	4.5 mm	6-5/8"	Black	10
MD 5	5 mm	6-5/8"	Black	10
MD5 5	5.5 mm	6-5/8"	Black	10
MD 6	6 mm	6-5/8"	Black	10
MD 7	7 mm	6-5/8"	Black	10
MD 8	8 mm	6-5/8"	Black	10
MD 9	9 mm	6-5/8"	Black	10
MD1 0	10 mm	7"	Black	10
MD1 1	11 mm	7"	Black	10

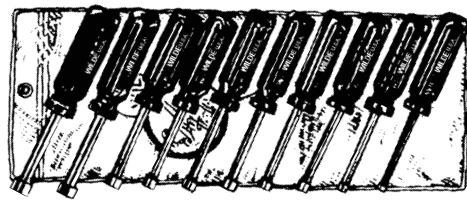

SMD910	10-Pc. Metric Hex Nut Driver Set. Contains one each MD4-MD11 in a vinyl pouch.	5
--------	--	---

SCREW STARTERS & TORX® DRIVERS	Cat. No.	Description	Std. Pk.
--------------------------------	----------	-------------	----------

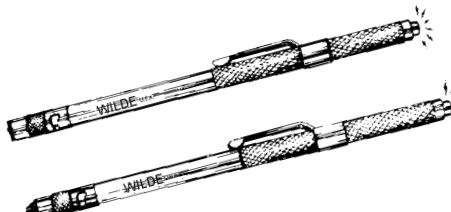
	175	5-5/8" Slotted Screw Starter. Aluminum knurled handle. Magnet end. Alloy steel screw starter bit. Pencil clip.	5
	175A	5-3/4" Phillips Screw Starter. Aluminum knurled handle. Magnet end. Alloy steel screw starter bit. Pencil clip.	5

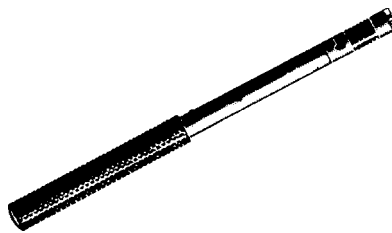
	656	2-1/2" Screw Starter. Aluminum. Withstands 8 lb. pull. Auto release. Duralumin handles, steel gripping bits. 1/4" Nib.	5
	657	5-1/2" Screw Starter. Aluminum. Withstands 8 lb. pull. Auto release. Duralumin handles, steel gripping bits. 1/4" Nib.	5
	658	9-1/2" Screw Starter. Aluminum. Withstands 8 lb. pull. Auto release. Duralumin handles, steel gripping bits. 1/4" Nib.	5

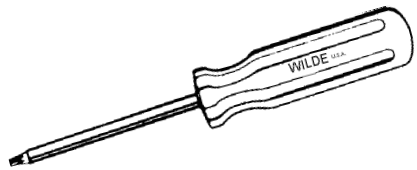
	T10	Torx Driver Size TX10	5
	T15	Torx Driver Size TX15	5
	T20	Torx Driver Size TX20	5
	T25	Torx Driver Size TX25	5
	T27	Torx Driver Size TX27	5
	T30	Torx Driver Size TX30	5
	TS35	6-Pc. Torx Driver Set. Contains one each T10-T30 in a sturdy vinyl pouch.	5

® Registered Trademark of Camcar Div. of Textron, Inc.



PLIERS

PUNCHES, CHISELS & PRY BARS

WRENCHES

SCREWDRIVERS

PLUMBING & INDUSTRIAL

AUTOMOTIVE

SERVICE TOOLS

DISPLAYS

## SAFETY RULES FOR HAND TOOLS

- Always use the right size and type of tool for the job being done. Keep tools in proper working condition. Never alter a tool from its original condition.
- Protect your eyes. Always wear safety goggles when using tools; particularly when using punches, chisels, hammers, power tool attachments and cutting tools.
- Ordinary plastic dipped handles are designed for comfort —not electrical insulation.
- Never use a tool as a hammer unless manufactured for that purpose.
- When possible, always pull on a wrench handle rather than push and adjust your stance to prevent a fall.
- Never use a pipe extension or other form of "cheater" to increase the leverage of any wrench. Never use a hammer on any wrench, other than a striking face wrench that is designed to be struck.
- Adjustable wrenches should be tightly adjusted to the nut and pulled so that the force is on the side of the fixed jaw.
- Select a wrench whose opening exactly fits the nut. Always seat the wrench straight on the nut—do not cock the tool when turning.
- Ratchet mechanisms should be cleaned and lubricated periodically with light grade oil.
- Pliers should not be used for cutting hardened wire unless manufactured for that purpose. Always cut at right angles— don't rock from side to side when cutting.
- Always strike squarely with the hammer striking face parallel to the surface being struck. Avoid glancing blows and over and under strikes. Never strike an object with the side of a hammer. Do not strike one hammer with another hammer.
- Metal cutting chisels are intended for cutting, shaping and removing metal softer than the cutting edge itself. Never use these tools for cutting or splitting stone or concrete.
- Always strike the struck base of a chisel or punch squarely. The striking face of the hammer should have a diameter approximately 3/8" larger than the struck face of the punch or chisel.
- Never use a chisel or punch with a dull, chipped deformed cutting edge or point or mushroomed struck face.
- Use the right type of screwdriver with the right tip for the screw. Make sure the tip fits the screw slot, not too loose and not too tight.
- Never use screwdrivers with rounded edges or tips.
- Never use a screwdriver as a chisel, punch, scraper or pry bar. Use screwdrivers for screw driving only.
- Do not heat jaws of pullers when heating bearings or gears, as heating can change their temper. Do not use pullers with worn or damaged parts.
- Puller forcing screws should be kept clean and lubricated with medium grade oil. Puller should not be cocked at an angle when in use.
- When using slide hammer pullers, be sure hands are well away from hammer on the back end of the slide rod.
- Wilde Tool Co. cannot be responsible for injury or damage caused by tools improperly used, or from tools which have been abused or badly worn.

### FEDERAL DESCRIPTIONS

The Federal descriptions shown in this catalog are intended as a guide only for classification of types of tools and do not mean that, in every case, the tool is in full compliance with the Federal Specification indicated. When bidding on tools that require conformity to Federal Specifications contact our Government Contract Department at Wilde Tool Co. in Hiawatha, Kansas.



# PLUMBING & INDUSTRIAL TOOLS

## TAPE MEASURES

Wilde introduces our line of Tape Measures. 16' x 3/4" blade and 25' x 1" blade. Plus we have a 100' long Steel Tape which has long Extension handle for quicker wind-up. And a 6' Wood Extension Rule. Has graduated brass extension.  
See Page 48.

## PIPE WRENCHES

The six popular pipe wrench sizes, jaw capacities from 1" to 5". I-beam cast iron handles. Heat-treated alloy steel jaws.  
See Page 49.

## FLARING TOOLS

Makes S.A.E. 45° flare joints in copper, brass or aluminum tubing. Self-centering yolk with quick-opening bar and large wing nuts. By adding our 400-AD to our 400-45, you can produce double-lap flares in all sizes except 5/8" tubing.  
See Page 50.

## TUBING CUTTERS

Micrometer action tubing cutters with alloy cutter wheel. Capacity 1/8" to 1-1/8" O.D. Cuts hard or soft copper, aluminum tubing and thin-wall conduit. Enclosed feed mechanism protects threads. Reamer blade locks in open or closed position.  
See Page 50.

## AVIATION & METAL CUTTING SNIPS

Three Aviation Snips cut right, left and straight. Heat treated alloy steel cuts 18 gauge cold rolled sheet metal. Serrated jaws. All snips have long lasting keen cutting edge.  
See Page 55.



## BRASS HAMMERS

Non-Marring. Non-Sparking.  
See Pages 53.

## HACK SAWS

All metal frame with comfortable pistol grip handle. Blades can be indexed to four positions. Adjustable for 8, 10 & 12 inch blades. Frame does not fall apart when blade is removed. (10" blade included).  
See Page 51.

## EXTRACTORS

Designed with a gradual taper and long flutes machined close to the cutting edges to permit the tightest grip. Forged from alloy steel. Industrial black finish. Meets Government Spec. No. GGG-E-936C.  
See Page 53.

## WILDE HANDLE PULLER

To remove handle, turn long threaded stem up until tip clears handle. Place arms under handle and bring sliding washer down until snug. Turn threaded stem down into screw hole until handle is free.  
See Page 52.



Remove larger handles with longer adjustable puller arms.  
See Page 52.



Fold-Up Hex Key Wrench Set 9 Pieces.  
See Page 52.

Ball Tip L- Shape Hex Key Wrenches.  
See Page 52.

T-Handle Hex Key Wrenches.  
See Page 52.

Standard L-Shape Hex Key Wrenches.  
See Page 52.

## HAMMERS & SLEDGES

Taper design eliminates possibility of handle coming off. Handle is made from strong hickory wood. Head is heat treated for toughness. "Rim-Tempered" face reduces chipping. New forged and heat treated sledge hammers. In 16" and 36". Available in double face and cross pein styles.  
See Pages 57 & 58.

PLIERS

PUNCHES, CHISELS & PRY BARS

WRENCHES

SCREWDRIVERS

PLUMBING & INDUSTRIAL

AUTOMOTIVE

SERVICE TOOLS

DISPLAYS



PLIERS  
 PUNCHES, CHISELS & PRY BARS  
 WRENCHES  
 SCREWDRIERS  
 PLUMBING & INDUSTRIAL  
 AUTOMOTIVE  
 SERVICE TOOLS  
 DISPLAYS

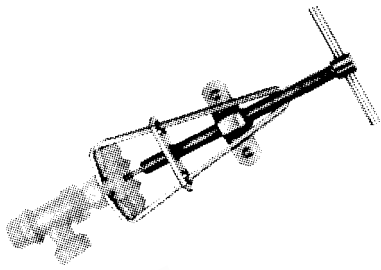

33P Faucet Handle Puller

5

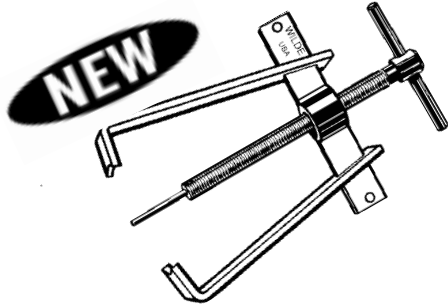

3870 Faucet Handle Puller.  
 Removes larger handles with longer adjustable puller arms. One piece cast cross bar for strength and durability. Puller features notches that ensure positive and equal positioning of puller arms on cross bar. Alloy steel components.

5

**Note:**  
 See other Pullers on Page 62.

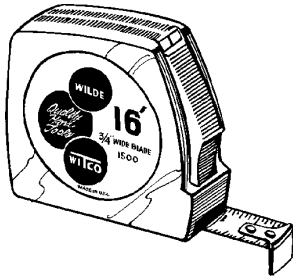

1500 16' Locking Tape.  
 3/4" wide yellow blade. Graduated in sixteenths. 16" stud center marks. Baked on blade coating. 3 rivet end hook. Positive Lock. Oversized numbers. Direct reading inside measurement. Unbreakable chrome plated case.

6

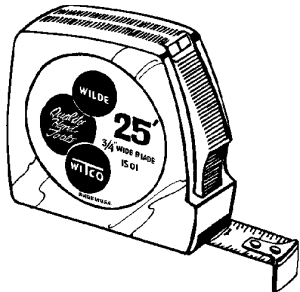

1501 25' Locking Tape.  
 1" wide yellow blade. Graduated in sixteenths. 16" stud center marks. Baked on blade coating. 3 rivet end hook. Positive Lock. Oversized numbers. Direct reading inside measurement. Unbreakable chrome plated case.

6

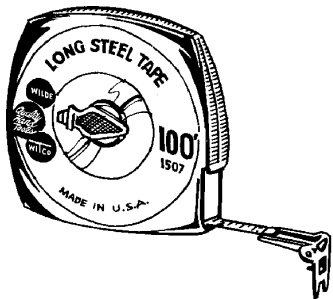

1507 100' Long Steel Tape.  
 3/8" wide yellow tape. Graduated in eighths. Pop-open folding handle has longer extension for faster rewinding. Chrome plated case.

6

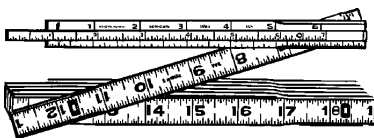

1510 6' Wood Extension Ruler.  
 Outside reading. 6" graduated brass extension. 16" stud center marks. Boxwood finish.

6

# PIPE WRENCHES

Cat. No.	Description	Std. Pk.
----------	-------------	----------



PW8	8" Heavy Duty Pipe Wrench. Jaw capacity 1". I-beam cast iron handle. Heat-treated alloy steel jaw.	6
PW10	10" Heavy Duty Pipe Wrench. Jaw capacity 1-1/2". I-beam cast iron handle. Heat-treated alloy steel jaw.	6
PW14	14" Heavy Duty Pipe Wrench. Jaw capacity 2". I-beam cast iron handle. Heat-treated alloy steel jaw.	6
PW18	18" Heavy Duty Pipe Wrench. Jaw capacity 2-1/2". I-beam cast iron handle. Heat-treated alloy steel jaw.	6
PW24	24" Heavy Duty Pipe Wrench. Jaw capacity 3". I-beam cast iron handle. Heat-treated alloy steel jaw.	6
PW36	36" Heavy Duty Pipe Wrench. Jaw capacity 5". I-beam cast iron handle. Heat-treated alloy steel jaw.	1

**NOTE:**  **PIPE WRENCH PLIER® — PAGE 5 & 13**

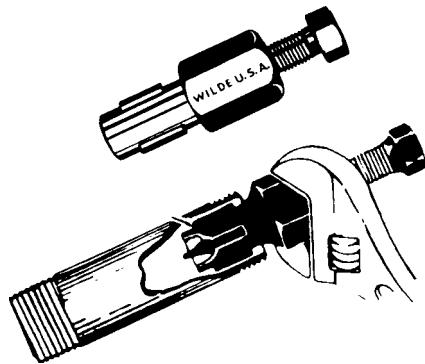

380	1/2" Internal Pipe Wrench. Expansion Blade. Loosens or tightens nipples, pipes & fittings.	5
383	3/4" Internal Pipe Wrench. Expansion Blade. Loosens or tightens nipples, pipes & fittings.	5
385	1" Internal Pipe Wrench. Expansion Blade. Loosens or tightens nipples, pipes & fittings.	5

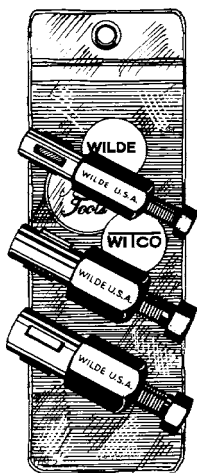

9033D	3-Pc. Internal Pipe Wrench Set. Contains one each #380, 383 and 385 in a hang-up, sturdy vinyl kit.	5
-------	---	---

**NOTE:** Internal Pipe Wrench eliminates damage to threads, walls and high polished finish.



FLARING TOOLS & TUBING CUTTERS	Cat. No.	Description	Std. Pk.
--------------------------------	----------	-------------	----------

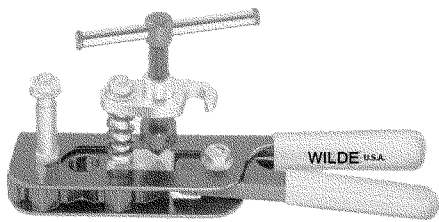

400-45 Flaring Tool produces single 45° lap flares in six sizes of tubing, 3/16", 1/4", 5/16", 3/8", 1/2" and 5/8" O.D. 5

PLIERS

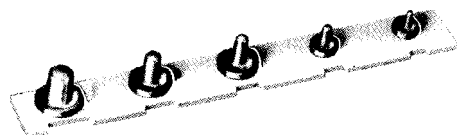

400-AD Form-A-Gage for #400-45. Produces double lap flares in five sizes of tubing, 3/16", 1/4", 5/16", 3/8", 1/2" O.D. 5

PUNCHES, CHISELS & PRY BARS

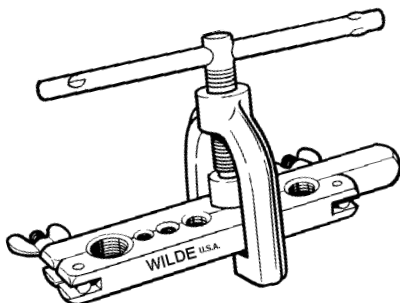

200 Flaring Tool makes S.A.E. 45° flare joints. Flares 3/16", 1/4", 5/16", 3/8", 7/16", 1/2", 5/8" O.D. 5

WRENCHES

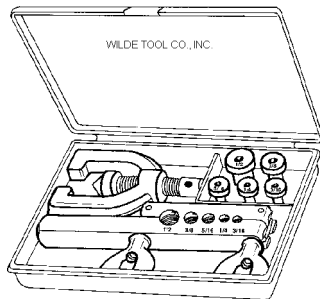

250DF Double Flaring Tool. Double flares 3/16", 1/4", 5/16", 3/8" & 1/2" O.D. In sturdy vinyl box. 5

SCREWDRIVERS

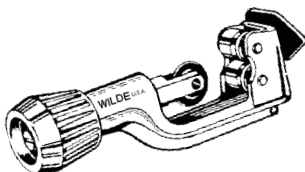

300 Tubing Cutter 1/8" to 1-1/8" O.D. Cutting wheel adjustment is internal. 5

PLUMBING & INDUSTRIAL

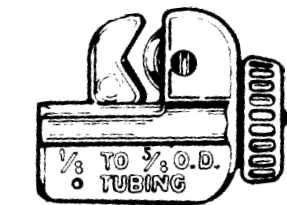

350 Tubing Cutter 1/8" to 1-1/8" O.D. Cutting wheel adjustment is external. 5

AUTOMOTIVE

SERVICE TOOLS



325 Midget Tubing Cutter. No rollers. Plated. 1/8" to 5/8" O.D. 3mm to 16mm O.D. 10

DISPLAYS

300W Cutter Wheel only for #300. 5  
 325W Cutter Wheel only for #325. 5  
 350W Cutter Wheel for #350. Also fits most popular brands. 5

HACK SAW & BLADES TORCH LIGHTER SET	Cat. No.	Description	Std. Pk.
--	-------------	-------------	-------------



553 Close quarters hand held hack saw. 5  
Accepts all standard hack saw blades.  
Can be used with broken blades of 4"  
or more. Blade included.

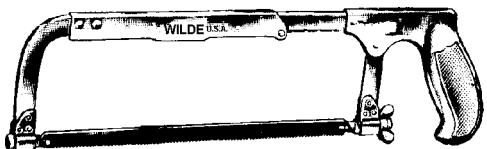

453 Pistol Grip Hack Saw, all metal 5  
frame. Adj. for 8, 10 & 12  
inch blades. Blade can be  
moved to 4 positions. Frame  
does not fall apart when blade  
is removed. 10" Blade included.

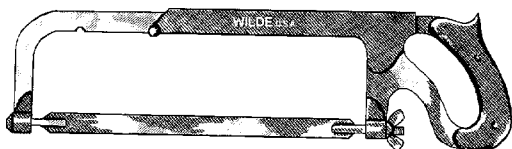

653 DeLuxe Pistol Grip Hack Saw. 5  
Extra heavy. High quality.  
Blade can be moved to 4  
positions. Frame does not fall  
apart when blade is removed.  
Adj. for 8, 10 & 12 inch blades.  
10" Blade included.

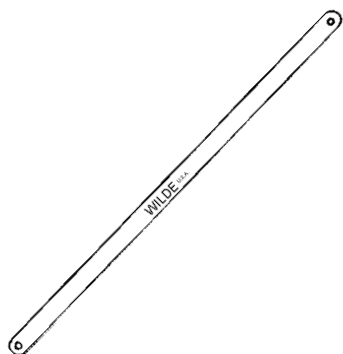

218 12" Hack Saw Blade. 18 Teeth/  
inch. Spring tempered alloy steel,  
shatterproof. 10

224 12" Hack Saw Blade. 24 Teeth/  
inch. Spring tempered alloy steel,  
shatterproof. 10

232 12" Hack Saw Blade. 32 Teeth/  
inch. Spring tempered alloy steel,  
shatterproof. 10

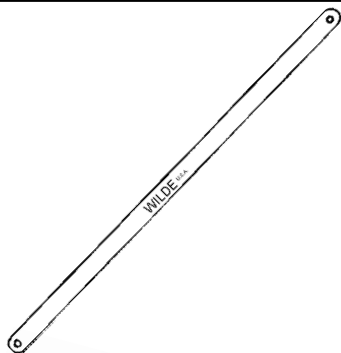

418 12" Economy Hack Saw Blades. 10  
18 Teeth/inch.

424 12" Economy Hack Saw Blades. 10  
24 Teeth/inch.

432 12" Economy Hack Saw Blades. 10  
32 Teeth/inch.

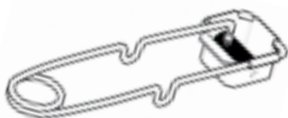

144 Torch Lighter made of heavy spring 10  
wire. Round type file with shield.  
8" Long.



144T Torch Lighter Renewal Tips. 40  
5 tips per pack.

PLIERS  
PUNCHES, CHISELS  
& PRY BARS  
WRENCHES  
SCREWDRIVERS  
PLUMBING &  
INDUSTRIAL  
AUTOMOTIVE  
SERVICE TOOLS  
DISPLAYS



**HEX KEY WRENCHES & SETS**      **Cat. No.**      **Description**      **Std. Pk.**

**L-SHAPE HEX KEY WRENCH**

		<b>Size</b>	<b>Fits Set Screw</b>	<b>Fits Cap Screw</b>	
	55	1/16"	5 & 6	2	100
	55A	5/64"	8	4	100
	56	3/32"	10	5 & 6	100
	57	1/8"	1/4"	8	100
	58	5/32"	5/16"	10	100
	59	3/16"	3/8"	1/4"	100
	60	7/32"	7/16"	5/16"	100
	61	1/4"	1/2" & 9/16"	-	100
	62	5/16"	5/8"	3/8" & 7/16"	100
	63	3/8"	3/4"	1/2"	50
	52R	10-Pc. Set Screw Wrench Set. Contains one each #55 to 63 incl., in vinyl kit.			5

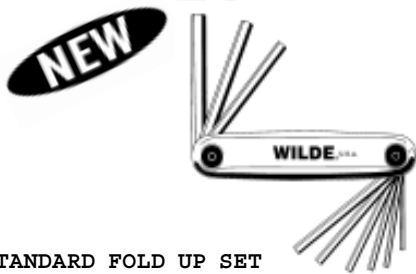

53R	9-Pc. Fold Up Hex Key Wrench Set. Contains one each 5/64", 3/32", 7/64", 1/8", 9/64", 5/32", 3/16", 7/32" and 1/4".	10
-----	---	----

**STANDARD FOLD UP SET**

**T-HANDLE HEX KEYS**

	<b>Size</b>	<b>Length</b>	<b>Handle Width</b>	
606E	3/32"	6"	3"	20
607E	7/64"	6"	3"	20
608E	1/8"	6"	3"	20
609E	9/64"	6"	3"	20
610E	5/32"	6"	3"	20
612E	3/16"	6"	4"	20
614E	7/32"	6"	4"	20
616E	1/4"	6"	4"	20
620E	5/16"	6"	6"	10
624E	3/8"	6"	6"	10
9106E	10-Pc. T-Handle Hex Key Set. Contains one each #606E to 624E inclusive in vinyl kit.			6

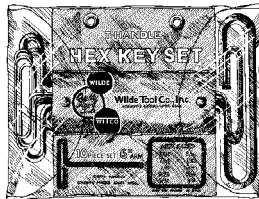
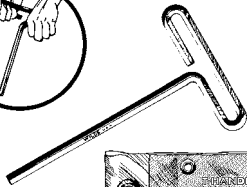

**BALL TIP L-SHAPE HEX KEY WRENCH**

	<b>Size</b>	<b>Length</b>		
902B	.050"	2.8"	20	
903B	1/16"	3.0"	20	
904B	5/64"	3.2"	20	
905B	3/32"	3.4"	20	
906B	7/64"	3.6"	20	
907B	1/8"	3.7"	20	
908B	9/64"	3.9"	20	
909B	5/32"	4.1"	20	
910B	3/16"	4.5"	20	
911B	7/32"	4.9"	20	
912B	1/4"	5.2"	20	
913B	5/16"	6.0"	10	
914B	3/8"	6.7"	5	
9139B	13-Pc. Ball Tip L-Shape Hex Key Set. Contains one each #902B to 914B inclusive in vinyl kit.			5



**SCREW EXTRACTORS & HAMMERS**

Cat. No. Description Std. Pk.

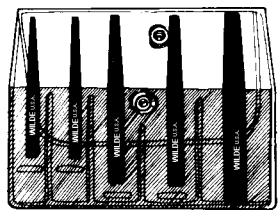
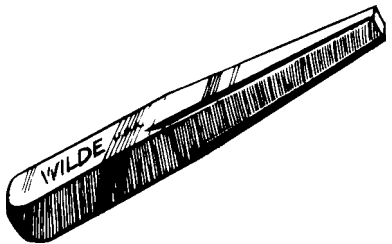

	Bolt Size	Pipe Size	Drill	
91	1/4"-5/16"	1/8"	1/8"	10
92	3/8"		3/16"	10
93	7/16"	1/8"	15/64"	10
94	1/2"-9/16"	1/4"	5/16"	10
95	5/8"	3/8"	3/8"	10
96	3/4"		15/32"	10
97	7/8"	1/2"	9/16"	10
98	1"-1-1/8"	1/2"	21/32"	10
99	1-1/4"-1-3/8"	3/4"	13/16"	10
89	4-Pc. Screw Extractor Set. Contains one each # 96, 97, 98 and 99, in a heavy, durable leatherette pouch.			5
90	5-Pc. Screw Extractor Set. Contains one each #91, 92, 93, 94 and 95 in a sturdy vinyl kit.			5



1001	<b>16 oz.</b> Curved Claw Hammer. Octagon neck. Supersteel. Flame treated hickory handle. 13".	4
1002	<b>20 oz.</b> Ripping Claw Hammer. Handle triple-wedged in eye for "Sure-Lock" fit. Flame treated hickory handle. 14".	4

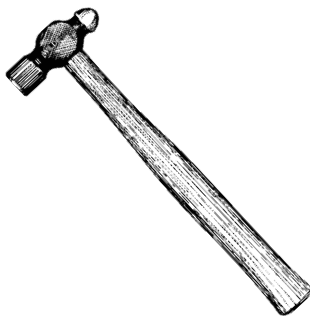

1003	<b>8 oz.</b> Ball Pein. Hickory handle. Black finish with polished face and pein. Chamfered face. 11-5/8".	4
1004	<b>16 oz.</b> Ball Pein. Hickory handle. Black finish with polished face and pein. Chamfered face. 14-1/4".	4
1005	<b>24 oz.</b> Ball Pein. Hickory handle. Black finish with polished face and pein. Chamfered face. 14-3/4".	4
1006	<b>32 oz.</b> Ball Pein. Hickory handle. Black finish with polished face and pein. Chamfered face. 15-1/4".	4

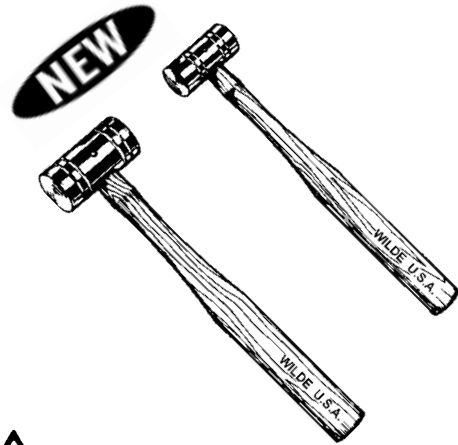

1008	<b>8 oz. BRASS</b> hammer. 10" OAL. 1" face diameter. 2.1" head.	5	Non-marring. Non-sparking. Handcrafted in the USA. Handle secured with brass pin.
1016	<b>16 oz. BRASS</b> hammer. 10 OAL. 1.25" face diameter. 2.6" head.	5	Heads are turned from quality 360 brass & hand polished.
1032	<b>32 oz. BRASS</b> hammer. 13" OAL. 1.5" face diameter. 4" head.	5	Used in machine shops, industrial, automotive & gunsmithing trades where hard drives are required to steel or iron surfaces without damage.
1080	<b>80 oz. BRASS</b> hammer. 16" OAL. 1.88" face diameter. 4.65" head.	5	



PLIERS

PUNCHES, CHISELS & PRY BARS

WRENCHES

SCREWDRIVERS

PLUMBING & INDUSTRIAL

AUTOMOTIVE

SERVICE TOOLS

DISPLAYS

# SLEDGE HAMMERS

Cat. No.	Description	Std. Pk.
----------	-------------	----------

- PLIERS
- PUNCHES, CHISELS & PRY BARS
- WRENCHES
- SCREWDRIVERS
- PLUMBING & INDUSTRIAL
- AUTOMOTIVE
- SERVICE TOOLS
- DISPLAYS

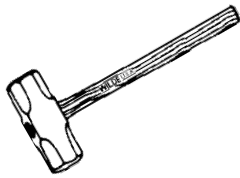

2DF	<b>2 lb.</b> Double Faced Sledge. Forged Steel. Heat Treated. 1-3/8" Face. 16" Length.	5
2-1/2DF	<b>2-1/2 lb.</b> Double Faced Sledge. Forged Steel. Heat Treated. 1-1/2" Face. 16" Length.	5
3DF	<b>3 lb.</b> Double Faced Sledge. Forged Steel. Heat Treated. 1-5/8" Face. 16" Length.	5
4DF	<b>4 lb.</b> Double Faced Sledge. Heat Treated. 1-3/4" Face. 16" Length.	5

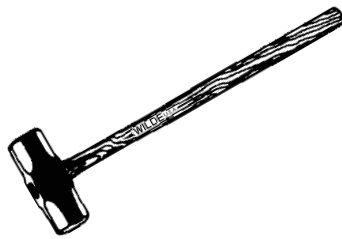

---

6DF	<b>6 lb.</b> Double Faced Sledge. Forged Steel. Heat Treated. 2-1/8" Face. 36" Length.	5
8DF	<b>8 lb.</b> Double Faced Sledge. Forged Steel. Heat Treated. 2-1/4" Face. 36" Length.	5
10DF	<b>10 lb.</b> Double Faced Sledge. Forged Steel. Heat Treated. 2-1/2" Face. 36" Length.	5
12DF	<b>12 lb.</b> Double Faced Sledge. Forged Steel. Heat Treated. 2-5/8" Face. 36" Length.	5
20DF	<b>20 lb.</b> Double Faced Sledge. Forged Steel. Heat Treated. 3-1/8" Face. 36" Length.	2

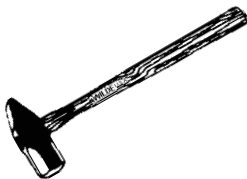



---

2CP	<b>2 lb.</b> Cross Pein Sledge. Forged Steel. Heat Treated. 1-3/8" Face. 16" Length.	5
3CP	<b>3 lb.</b> Cross Pein Sledge. Forged Steel. Heat Treated. 1-5/8" Face. 16" Length.	5
4CP	<b>4 lb.</b> Cross Pein Sledge. Forged Steel. Heat Treated. 1-3/4" Face. 16" Length.	5

**AVIATION & METAL CUTTING TIN SNIPS** Cat. No.

Description

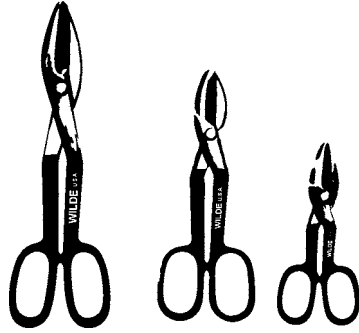
Std. Pk.



- 1SN Straight Pattern Snips. 1-3/4" Cutting edge. 7" Long.
- 2SN Straight Pattern Snips. 2-1/2" Cutting edge. 10" Long.
- 3SN Straight Pattern Snips. 3" Cutting edge. 12" Long.

- 12 • Hot drop-forged steel.
- Roll polish finish.
- 12 • Use traditional straight blade pattern snips for cutting wide curves to the left or right and for power straight cuts.
- 12



- 4SN Circular Pattern Snips. 1-3/4" Cutting edge. 7" Long.
- 5SN Circular Pattern Snips. 2-1/2" Cutting edge. 10" Long.
- 6SN Circular Pattern Snips. 3" Cutting edge. 12-3/4" Long.

- 12 • Hot drop-forged steel.
- Roll polish finish.
- 12 • Use circular blade pattern snips for cutting wide tight curves to the left or right and for cutting straight.
- 12

SPRING ACTIVATED LATCH

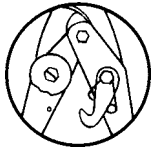

CANNOT CLOSE ACCIDENTLY

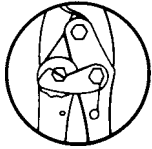

- 8SN 10" **RIGHT CUT** Aviation Snip. Green grips. 1-3/8" Cutting edge. Serrated blade. Heat treated alloy steel. Compound leverage.

- 10 • Moly steel & austemper heat treated for long-lasting cutting edge.
- Both blades serrated optimum 40 serrations per inch for maximum gripping power without scanning material.



- 9SN 10" **STRAIGHT CUT** Aviation Snip. Yellow grips. 1-1/2" Cutting edge. Serrated blade. Heat treated alloy steel. Compound leverage.

- 10 • Grade 8 center pivot bolt threaded into bottom blade to keep blades in adjustment longer and hold blade readjustment after extensive use.
- Heavy-duty half hard steel handles will not collapse from hand pressure.



- 10SN 10" **LEFT CUT** Aviation Snip. Red grips. 1-3/8" Cutting edge. Serrated blade. Heat treated alloy steel. Compound leverage.

- 10 • Finger or thumb actuated safety latch keeps blades securely closed when tool is in use.
- These regular blade pattern models are strong and versatile and can be used to cut a multitude of sheet materials.



PLIERS

PUNCHES, CHISELS & PRY BARS

WRENCHES

SCREWDRIVERS

PLUMBING & INDUSTRIAL

AUTOMOTIVE

SERVICE TOOLS

DISPLAYS

# NOTES



# AUTOMOTIVE TOOLS

## SWIVEL TYPE OIL FILTER WRENCHES

Unique Yoke and Link Assembly allows for a positive grip. Offering 2 popular sizes. For filters ranging in size from 2-7/8" - 3-1/4" and 4" - 4-3/8".

See Page 61.

**NEW**

## ADJUSTABLE OIL FILTER PLIER

Self adjusting, spring action plier. Allows for a full range of filter applications (2-1/4"-6"). Heavy duty forged handles for strength and leverage. Gripped.

See Page 61.

## VALVE LIFTERS

Heavy duty design. Hand, toggle and air operated for all types of valve work. Our complete line handles the most difficult valve jobs. All valve lifters are properly heat treated and plated.

See Pages 60 & 61.

## RING COMPRESSORS

Adaptive to all types of rings, brake being strong enough for the stiffest rings. Beaded edge prevents compressor from entering cylinder with piston. Will not oval or egg shape around piston skirt. 1, 2 or 4 tension bands available depending on the size of the piston.

See Page 64.

## PULLERS

Adjustable and reversible two and three jaw pullers. All built to withstand hard usage. Contrasting cadmium and black oxide. Steering Wheel Puller, Ball Joint Separator and Tie Rod End Pullers also available.

See Pages 62 & 63.

## FEELER GAUGES

Precision Gauges made of Imported Swedish Feeler Steel, hardened and tempered for long wear, ground and polished to an accuracy of one ten thousandths of an inch. All gauges are equipped with knurled lock nuts for quick release of blades facilitating the selection of size desired and also insertion of new blades. Sizes are permanently etched on blades.

See Pages 65.

## RING GROOVE CLEANER

For removing carbon from piston ring grooves from smallest to 6" without chattering, gouging, catching in oil holes or climbing out of groove. Rigid frame and radially held cutter prevents tilting which causes damage to the sides of the groove or cutting the bottom of the groove at an angle. Plated finish.

See Page 64.

## HONES

For brake cylinder work for servicing small engines. Strongly built, self-aligning, self-centering. Built to bottom in blind holes or resurface step-cylinders. Fine, medium and coarse grit stones available.

See Page 58.

## GLAZE BREAKERS

Flexible shaft stone type with long resilient spring action which forces the abrasive stones against the cylinder wall for proper glaze breaking and constantly maintained correct cutting pressure. Adjustable and preset tension. Fine, Medium and Coarse Stones available.

See Page 59.

PLIERS

PUNCHES, CHISELS  
& PRY BARS

WRENCHES

SCREWDRIVERS

PLUMBING &  
INDUSTRIAL

AUTOMOTIVE

SERVICE TOOLS

DISPLAYS



# HONES

Cat. No. Description Std. Pk.

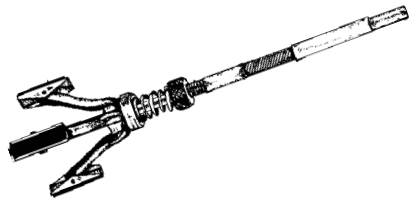

63DG Brake Cylinder Hone. Adjustable Tension. Flexible Shaft. 3/4" to 2-1/2" diameter. 1-1/8" Medium Grit Stones. Carded. 5

PLIERS

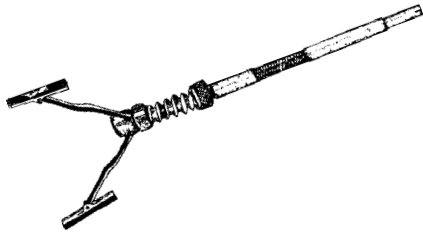

64FDG Brake Cylinder Hone for most small cars/Imports. Adjustable Tension. Flexible Shaft. 1/2" thru 2-1/2" diameter. 1-1/8" Medium Grit Stones. Carded. 5

PUNCHES, CHISELS & PRY BARS

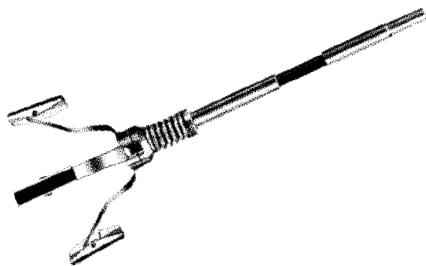

67DG Brake Cylinder Hone. Preset Tension, self-adjusting spring. Flexible Shaft Expansion is controlled on a flat surface. 3/4" to 2-1/4" diameter. 1-1/8" Medium Grit Stones. Carded. 5

WRENCHES

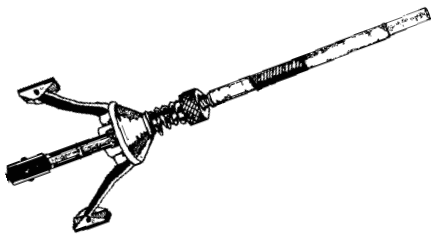

68 Cylinder Hone for Cycle, Lawnmower & Outboard shops. Flexible Shaft. Capacity 1-1/4" to 3-1/2" diameter. 3/4" Stones. Carded. 5

SCREWDRIVERS

PLUMBING & INDUSTRIAL

68A Same as #68 except with 2" Stones. 5

AUTOMOTIVE

SERVICE TOOLS

DISPLAYS

Fine Grit = 400  
Medium Grit = 240  
Coarse Grit = 100

63-1 1-1/8" Medium Grit Stone Set 10 for 63DG, 67DG

63-14 1-1/8" Fine Grit Stone Set. 5 for 63DG, 67DG

63-100 1-1/8" Coarse Grit Stone Set. 5 for 63DG, 67DG

63-21 2" Medium Grit Stone Set. 5 for 63DG, 67DG, 68A

63-24 2" Fine Grit Stone Set. 5 for 63DG, 67DG, 68A

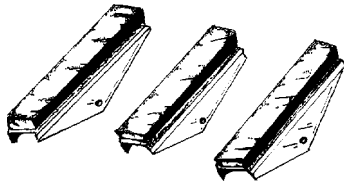

63-34 3/4" Fine Grit Stone Set. 5 for 63DG, 67DG, 68

64-1 1-1/8" Medium Grit Stone Set. 5 for 64FDG

64-14 1-1/8" Fine Grit Stone Set. 10 for 64FDG

# GLAZE BREAKERS

Cat. No.	Description	Std. Pk.
----------	-------------	----------

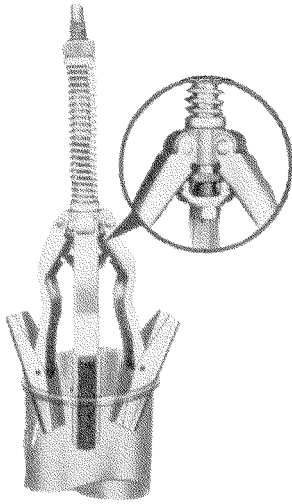

60DGS	Glaze Breaker. Stone type. 2" to 5-1/2" dia. 3" Long Medium Grit Stones. Carded.	5
-------	--	---

61DG	Glaze Breaker. Preset Tension. Flexible Shaft. 2" to 5" dia. 3" Long Medium Grit Stones. Carded.	5
------	--	---

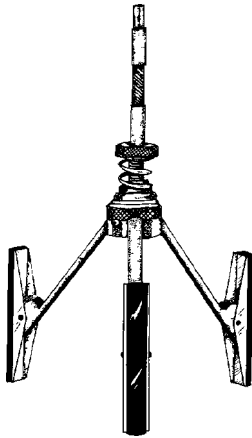

62DG	Large Glaze Breaker. Preset Tension. Flexible Shaft. 2" to 7" dia. 4" Long Medium Grit Stones. Carded.	5
------	--	---

62DGS	Large Glaze Breaker. Stone Type. 2" to 7" dia. 4" Long Medium Grit Stones. Carded.	5
-------	--	---

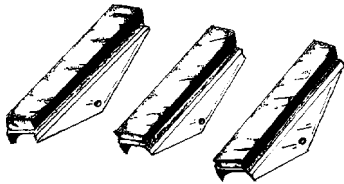

61-1S	3" Coarse Grit Stone Set.	10	for 60DGS, 61DG, 62DG, 62DGS
-------	---------------------------	----	------------------------------

61-2S	3" Medium Grit Stone Set.	10	for 60DGS, 61DG, 62DG, 62DGS
-------	---------------------------	----	------------------------------

61-4S	3" Fine Grit Stone Set.	10	for 60DGS, 61DG, 62DG, 62DGS
-------	-------------------------	----	------------------------------

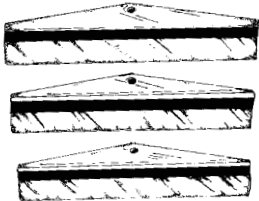

62-2S	4" Medium Grit Stone Set.	10	for 62DG, 62DGS
-------	---------------------------	----	-----------------

62-4S	4" Fine Grit Stone Set.	10	for 62DG, 62DGS
-------	-------------------------	----	-----------------

PLIERS

PUNCHES, CHISELS  
& PRY BARS

WRENCHES

SCREWDRIVERS

PLUMBING &  
INDUSTRIAL

AUTOMOTIVE

SERVICE TOOLS

DISPLAYS



# VALVE LIFTERS

Cat.  
No.

Description

Std.  
Pk.

- PLIERS
- PUNCHES, CHISELS & PRY BARS
- WRENCHES
- SCREWDRIVERS
- PLUMBING & INDUSTRIAL
- AUTOMOTIVE
- SERVICE TOOLS
- DISPLAYS

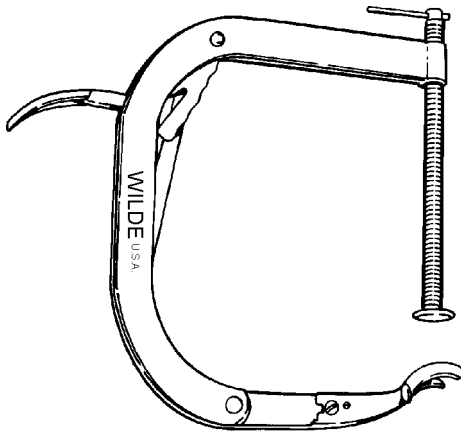

615

"C" Clamp Valve Lifter. 10-1/2" High, 9-3/4" Wide. Cap. 1" to 2-1/2". Comes with 3 sets of jaws, #612, 613C & 608. Quick Change Jaws.

1

#615 designed for "L" head & valve-in engines. One handed control lock & release. Spring release frees other hand for replacing keepers or locks on valve stem. Quickly adjusts for any valve stem length. One simple adjustment with pin operated screw on the first set of valves sets clamp for the balance of the springs. Heavy duty cam locking handle gives leverage for handling the stiffest of springs. Full thread length on screw adjusting post provides maximum capacity.

613C

Medium offset jaws fit #615 & #700. Cap. 1" to 2". Jaws are pictured on #615.

5

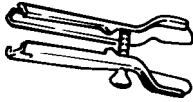

608

Large Straight Jaws fit #615 & #700. Cap. 1-1/2" to 2-1/2".

5



612

Small Straight Jaws fit #615 & #700. Cap. 7/8" to 1-3/4".

5

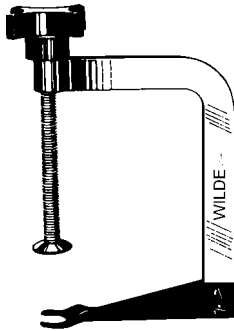

600

Small Engine Valve Lifter. For air or water cooled 4-cycle engines with spring diameter up to 1-1/16".

5



600-3A

Small Jaw replacement for #600.

5



600-3B

Large Jaw replacement for #600.

5

**VALVE LIFTERS &  
OIL FILTER WRENCHES**

Cat.  
No. Description

Std.  
Pk.

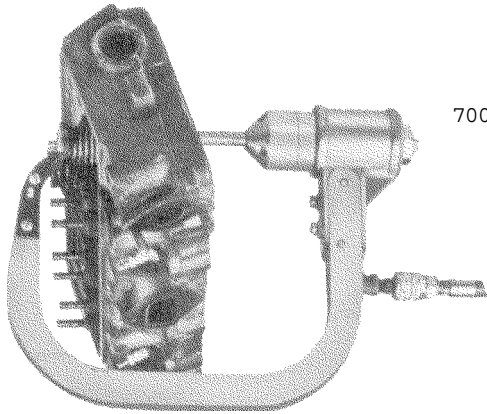

700

Air Operated "C" Clamp Valve Lifter. Equipped with three pairs of jaws, #608, 612 & 613C. Height 9-3/4". Width 7". Cap. 1" to 2-1/2".

1

**#700** Just 2 fingers do the work! Fully controlled "C" type valve lifter that compresses the heaviest springs in a fraction of a second. Controlled release action is a must when keys or keepers are being replaced. Operates with on-line pressure of 90-125 lbs. & develops pressure equal to 3X the line pressure. Features completely paralleled lift that will not bend valve stem. Ideal for all late model cars, trucks, buses, tractors, marine & industrial engines.

PLIERS

PUNCHES, CHISELS & PRY BARS

WRENCHES



513

Oil Filter Wrench. Capacity 2-7/8" - 3-1/4". Swivel type. Unique yoke and link assembly for positive grip.

5

514

Oil Filter Wrench. Capacity 4" - 4-3/8". Swivel type. Unique yoke and link assembly for positive grip.

5

SCREWDRIVERS

PLUMBING & INDUSTRIAL

AUTOMOTIVE

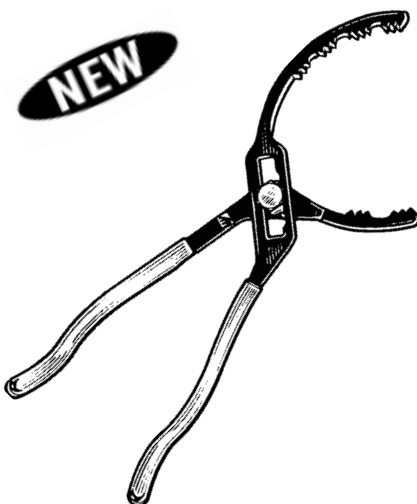

515

Adjustable Oil Filter Plier. Self adjusting, spring action plier allows for a full range of filter applications (2-1/4"-6"). Heavy duty forged handles for strength and leverage. Grippled.

5

SERVICE TOOLS

DISPLAYS



# PULLERS

Cat. No.	Description	Std. Pk.
----------	-------------	----------

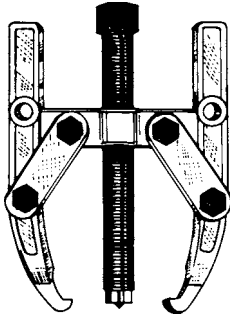

950	4" Adjustable 2 Jaw Gear Puller. 2 Positions. Reach 3-1/2". Spread 4". Center Screw 3/8"-24 x 4-3/4". 2 Ton.	5
-----	--	---

- Forged alloy steel.
- Fully heat treated.
- Contrasting bright luster plate & black oxide.

952	7" Adjustable 2 Jaw Gear Puller. 2 Positions. Reach 5-1/2". Spread 7". Center Screw 9/16"-20 x 6-3/8". 5 Ton.	5
-----	---	---

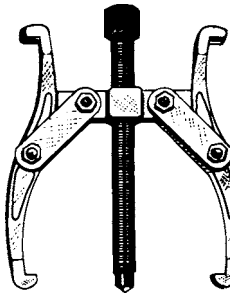

954	6" Reversible 2 Jaw Gear Puller. Reach 3-1/2". Spread 6". Center Screw 9/16"-20 x 6-3/8". 5 Ton. Jaws have wide faces on one end & narrow faces on the other.	5
-----	--	---

956	9" Reversible 2 Jaw Gear Puller. Reach 5-1/2". Spread 9". Center Screw 11/16"-18 x 9-3/32". 7 Ton. One end of jaw has a slot for cap screw pulling of tapped gears & pulleys.	5
-----	--	---

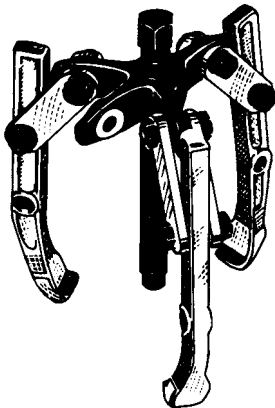

951	4" Adjustable 3 Jaw Gear Puller. 3-Jaw feature gives added stability. Reach 3-1/2". Spread 4". Center Screw 3/8"-24 x 4-1/4". 2 Ton.	5
-----	---	---

953	8" Adjustable 2 & 3 Jaw Gear Puller. 2 Positions. Reach 5-1/2", Spread 8". Center Screw 9/16"-20 x 6-3/8". 5 Ton.	5
-----	---	---

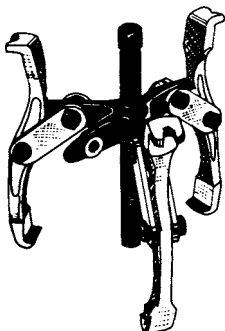

955	7" Reversible 2 & 3 Jaw Gear Puller. Reach 3-1/2". Spread 7". Center Screw 9/16"-20 x 6-3/8". 5 Ton.	5
-----	--	---

957	10" Reversible 2 & 3 Jaw Gear Puller. Reach 5-1/2". Spread 10". Center Screw 11/16"-18 x 9-3/32". 7 Ton.	5
-----	--	---

PLIERS

PUNCHES, CHISELS  
& PRY BARS

WRENCHES

SCREWDRIVERS

PLUMBING &  
INDUSTRIAL

AUTOMOTIVE

SERVICE TOOLS

DISPLAYS

# PULLERS

Cat. No.	Description	Std. Pk.
----------	-------------	----------

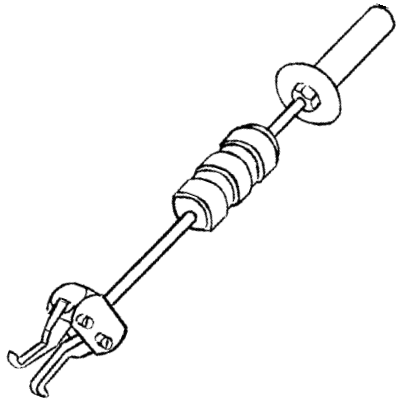

958	Pilot Bearing Puller for removing sleeve type bearings from 1/2" to 1-1/2" inside dia. Center rod spreads jaws for tight fit. A few light taps with the sliding hammer and the bearing is removed. Individually boxed. Center Rod is 1/2" - 13 x 13".	5
-----	---	---

PLIERS

PUNCHES, CHISELS & PRY BARS

WRENCHES

SCREWDRIVERS

PLUMBING & INDUSTRIAL

AUTOMOTIVE

SERVICE TOOLS

DISPLAYS

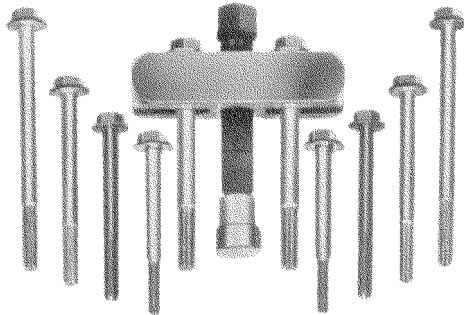

959	Steering Wheel Puller. Cross arm is 4" long, made of 1" square steel. Center screw is 5/8-18 x 5". The center screw has a floating swivel for maximum flexibility. Five sets of screws included: 2 each 1/4" - 28 x 3". 2 each 5/16" - 24 x 3-1/2". 2 each 5/16" - 18 x 4-1/2". 2 each 3/8" - 16 x 4". 2 each M8 - 1.25 x 80mm.	5
-----	--	---

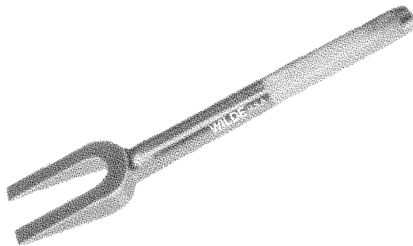

962	Ball Joint Separator. Made of alloy heat-treated steel forging, bright luster plate finish. Individually boxed. Opening 15/16", Length 11-7/8".	5
-----	---	---



964	Tie Rod End Puller. Made from single piece of alloy heat-treated drop forging. Bright luster plate finish. Individually boxed. Opening 21/32", Length 11-7/8".	5
-----	--	---



# RING TOOLS

Cat. No. Description Std. Pk.

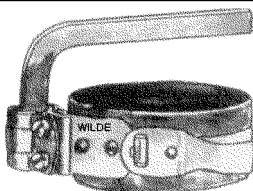

44 Outboard Motor Ring Compressor. Band is 13/16" high. Range 1-3/8" to 3-1/2". Release catch opens for quick removal. 5

44-2 Twin Compressor Set and handle. 5 #44-2 TO BE DISCONTINUED WHEN STOCK IS DEPLETED

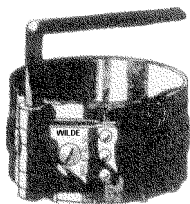

48 Midget Ring Compressor for foreign cars and small gas engines. 2" high compression band. Cap. 1-1/2" to 3". 5

51 Piston Ring Compressor. Adaptable to all types of rings. 2-1/2" high compression band. Range 2-1/8" to 5". 5

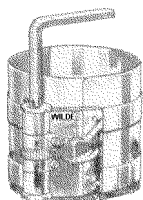

66 Ring Compressor, Ratchet type. Self locking, heavy duty ratchet. 3-1/2" Twin bands. Range 2-1/8" to 5". 5

67 Ring Compressor, Ratchet Self locking, heavy duty ratchet. 3-1/2" Twin bands. Range 3-1/2" to 7". 5

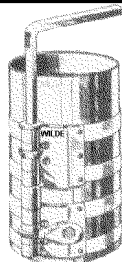

69 Jumbo Ring Compressor for Bus and Tractor. 4 Tension Bands and 2 winding spools. 6-1/2" High. Range 3-1/2" to 7". 5

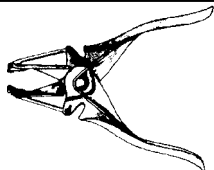

31 Piston Ring Expander. Handles all sizes of piston rings. Flat gripping surface will not damage rings. Heat treated, plated finish. 6-1/2" Long. 5

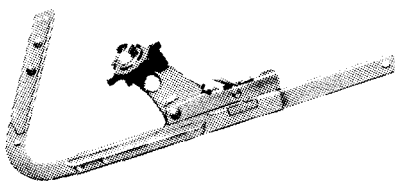

49 Ring Groove Cleaner. Rigid frame and radially held cutter. Compensating spring. Cutter wheel sizes below. 5

47 Ring Groove Cleaner, (for late V8 motors). Cutter wheel includes sizes below. 5

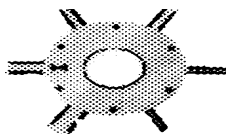

47A 2 Extra Cutters in 1/16", 5/64", 3/32", 1/8", 5/32", 3/16" and in Metric 2mm, 2.5mm, 3.0mm, 4.0mm and 4.5mm. 5

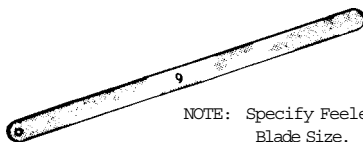

NOTE: Specify Feeler Gauge Blade Size.

512B Six 12" Blades .003 to .028 incl. 1  
 512BE Six 12" Blades .0015 and .002 1  
 512BL Six 12" Blades .030, .032, .035, .040 1

PLIERS

PUNCHES, CHISELS & PRY BARS

WRENCHES

SCREWDRIVERS





PLUMBING & INDUSTRIAL

AUTOMOTIVE

SERVICE TOOLS

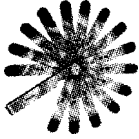
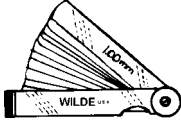
DISPLAYS

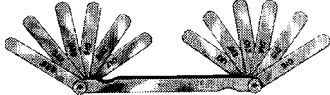
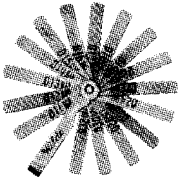
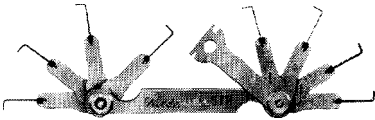
# GAUGES

	Cat. No.	Description	Std. Pk.	Blade Measurements		
	476	GO-NO-GO Gauge. Contains fifteen 1/2" wide by 3-5/16" long step ground blades.	5	.006/.008 .007/.009 .008/.010 .009/.011 .010/.012 .011/.013 .012/.014 .013/.015	.014/.016 .015/.017 .016/.018 .017/.019 .018/.020 .019/.021 .020/.022	
	499	Metric Ignition Gauge. Contains thirteen 1/2" x 3" blades.	5	.050 .100 .150 .200	.250 .300 .400 .500 .600	.600 .700 .800 .900 1.000
	500	Master Gauge. Contains twenty-five 1/2" wide by 3" long blades.	6	.0015 .002 .003 .004 .005 .006 .007 .008 .009	.010 .011 .012 .013 .014 .015 .016 .018	.020 .022 .024 .025 .028 .030 .032 .035
	501	Standard Gauge. Contains ten 1/2" wide by 3" long blades.	5	.002 .003 .004 .005	.006 .007 .008	.010 .012 .015
	504	Ignition Gauge. Contains twelve 1/4" wide by 1-3/4" long blades.	5	.011 .012 .013 .014	.015 .016 .017 .018	.019 .020 .022 .025
	510	Master Ignition Gauge. Contains sixteen 1/4" wide by 1-3/4" long blades.	5	.011 .012 .013 .014 .015 .016	.017 .018 .019 .020 .022	.024 .025 .028 .030 .032
	578	Spark Plug Gauge. Contains eight 90° offset wire blades. One electrode bending tool.	5	.020 .025 .028	.030 .032 .034	.035 .040
	589	Universal O.H.V. Gauge for V8 engines. Contains sixteen 1/2" wide by 3-5/16" long blades with 45° offset for checking valve clearances.	5	.009 .010 .011 .014 .015 .016	.017 .018 .019 .020 .021	.023 .024 .025 .026 .027

PLIERS

PUNCHES, CHISELS & PRY BARS

WRENCHES

SCREWDRIVERS

PLUMBING & INDUSTRIAL

AUTOMOTIVE

SERVICE TOOLS

DISPLAYS



# NOTES



# SERVICE TOOLS

## BLOW GUNS

Pressure guns with trigger controlled air from a whisper to full line pressure. Spring loaded control valve with no cut-off. Cadmium plated for long life.

See Page 68.

## SCRAPERS & AWLS

Gasket scraper made of forged alloy steel with a sharp chisel edge. Insulite handle. The scratch awls are a tough, hard tool steel punch. Goes through body metal.

See Page 71.



## NEW SCRAPER SIZES

Same style as our standard one scraper. One with exposed blade of 5" x 1" face and the other 8" x 1/2".

See Page 71.

## HOSE CLAMP PLIERS

For removing and installing spring wire hose clamps. Deep slots in jaws hold clamp securely. Pawl automatically locks plier in any of three positions. Jaws swivel through 180°.

See Page 72.

## INSPECTION MIRRORS

A complete line of inspection mirrors for industrial, electronic, aircraft and automotive uses. Your choice of Oval, Round or Rectangular shape mirrors. Some have telescopic handles and adjustable heads. Replacement mirrors available.

See Page 69.

## MAGNETIC PICK-UP TOOLS

Contain a powerful Alnico Magnet, retrieves metal objects in hard to reach places. Your choice of handles, either flexible, telescopic or pocket styles available.

See Page 70.

## MECHANICAL FINGER

Can be used as a temporary clamp for small parts. Can be bent into an S shape or at 90° without springing back. Has 15" reach. For retrieving small parts or pulling wires through dashes.

See Page 70.

## AXLE RETHREADING DIE

Can be used for rethreading axles without removing the axle from the housing. The Die is split for quick application and is fitted to the threads at the back end of the axle and rechases threads through the damaged portion. Drop forged steel, Heat Treated, Nickel plated.

See Page 72.

## HOOK AND PICK SET

Ideal for separating wires, removing small fuses, "O" rings, retrieving washers and loose parts too small to pick up with your fingers. Each hook and pick is made of high carbon polished steel and is permanently attached to a hex shaped aluminum handle.

See Page 70.

## FLEXIBLE DRIVERS

A versatile tool with swivel head and a flexible working end which can be bent to reach difficult places. Long enough and small enough to slip between wires and other obstructions.

See Page 72.

## HEADLIGHT SPRING TOOL

Special punched end allows pushing or pulling against spring tension. Hardened bit is nickel-chrome plated with fluted plastic handle.

See Page 71.

## COTTER KEY EXTRACTOR

Work in like a cork screw and zip cotter keys out on brake assemblies etc. Also useful for removing snap lock rings, or removing the rubber seats at the bottom of replaceable seats on International line of trucks and tractors.

See Page 71.



## EXTENDED LENGTH COTTER KEY EXTRACTOR

Where longer reach is necessary. Used in all markets, especially aircraft industry.

See Page 71.

PLIERS

PUNCHES, CHISELS & PRY BARS

WRENCHES

SCREWDRIVERS

PLUMBING & INDUSTRIAL

AUTOMOTIVE

SERVICE TOOLS

DISPLAYS



# BLOW GUNS

Cat. No. Description Std. Pk.

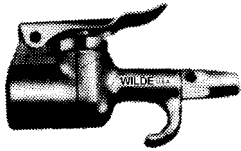

301S Short Nozzle Blow Gun. Spring loaded control valve with no cut off. 2-1/8" Long. Full line pressure nozzle, single finger control. Meets OSHA requirements. 5

PLIERS

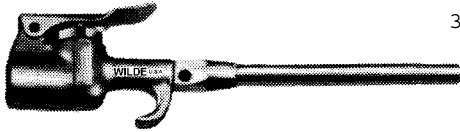

302S Medium Tube Blow Gun. Same as #301S but with 4" Tube Nozzle. 6-1/8" Overall Length. Meets OSHA requirements. 5

PUNCHES, CHISELS & PRY BARS



303S Long Tube Blow Gun. Same as #301S but with 9-7/8" Tube Nozzle. 12" Overall Length. Tubes may be bent for individual use. Meets OSHA requirements. 5

WRENCHES

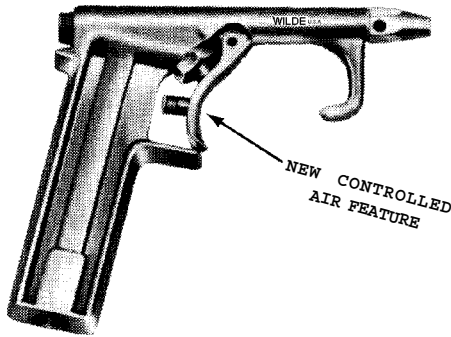

321S Controlled Air Blow Gun. Dual Air Inlets for Overhead air source or underbench or floor air source. Interchangeable Plug, Pistol Grip Handle Front Hanging Hook. Meets OSHA Requirements when used on line pressure from 100 to 135 PSI. Will deliver 30PSI or less. 5

SCREWDRIVERS

PLUMBING & INDUSTRIAL

AUTOMOTIVE



301-3S Nozzle Only for #301S 5



302-3S Nozzle Only for #302S 5









303-3S Nozzle Only for #303S 5

SERVICE TOOLS

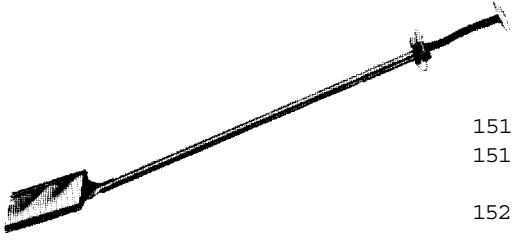
DISPLAYS

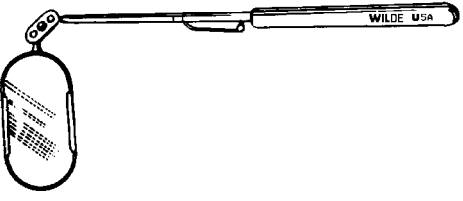
NOTE: All Nozzles are interchangeable with any of the above Blow Guns.

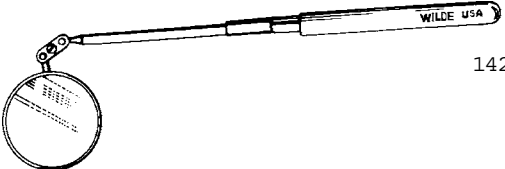
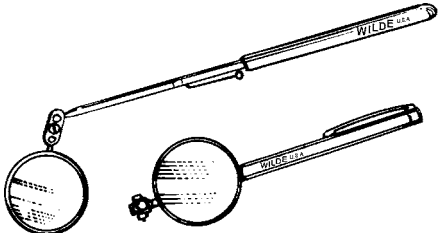
# MIRRORS

	Cat. No.	Description	Std. Pk.	
	151	Tilting Inspection Mirror swings to angle desired by pressing plunger, locks at any angle & returns to straight position by tripping lock. Full 90° swing tilt. 16-1/2" Long, Rectangle Mirror 1-11/16" x 2-9/16".	5	<b>Mirrors are not guaranteed.</b>
	151P	#151 with unbreakable plastic mirror.	5	
	151-1	Replacement Glass for #151.	5	
	152	Tilting Inspection Mirror. Same as #151 except is 11" Long with a 1-1/4" x 1-1/2" Rectangular Mirror.	5	
	152-1	Replacement Glass for #152.	5	
	<hr/>			
	157	Inspection Mirror. Oval Shaped. Spring loaded ball socket adjustment. Spring pressure maintains adj. for any position on 360°. 8-1/2" Long, 1" x 2" Mirror.	5	
	<hr/>			
	157A	#157 with a Telescopic Handle. 4-1/2" Expands to 19-1/2".	5	
	157-1	Replacement Glass for #157.	5	
<hr/>				
	142	Inspection Mirror. Telescopic Handle 10" to 14" Length. 2-1/4" Dia. Mirror. Ball Joint Adjustment.	5	
	142-1	Replacement Glass for #142.	5	
<hr/>				
	143	Inspection Mirror. 8" Long, 1-1/4" Round Mirror, Ball Joint Adjustment.	5	
	143A	#143 with Telescopic Handle. Extends 4-1/2" to 18-1/2".	5	
	143-1	Replacement Glass for #143.	5	
	145	Plane Inspection Mirror. 7" Long, 7/8" Round Mirror, 135° Fixed Position, Vinyl Grip.	5	
<hr/>				
	147A	Telescopic Inspection Mirror, 4-1/2" to 18" Long, 7/8" Round Mirror. Double ball adj. head, pocket clip.	5	
	147A-1	Replacement Glass for #147A.	5	

PLIERS

PUNCHES, CHISELS & PRY BARS

WRENCHES

SCREWDRIVERS

PLUMBING & INDUSTRIAL

AUTOMOTIVE

SERVICE TOOLS

DISPLAYS



# PICK UP TOOLS

PLIERS  
PUNCHES, CHISELS & PRY BARS  
WRENCHES  
SCREWDRIVERS  
PLUMBING & INDUSTRIAL  
AUTOMOTIVE  
SERVICE TOOLS  
DISPLAYS

Cat. No. Description Std. Pk.

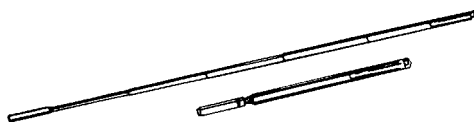

158A Magnetic Telescopic Pocket Pick Up Tool. Closed length 5-1/2", extends to 18-1/8". Handle & head made of Chrome plated Brass. Pocket Clip attached. 5



159A Magnetic Telescopic Pick Up Tool. Neodymium-Iron-Boron extra high flux magnet picks up to 1-1/2 lbs. Closed length 5-7/8", extends to 25-9/16". Pocket clip attached. 5

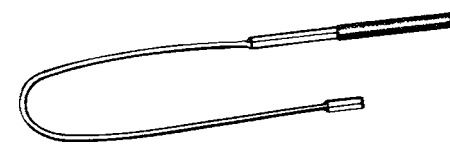

162V 21-1/2" Flexible Magnetic Pick Up Tool. Knurled Handle. Holds flex. Picks up ferrous metal to 1-1/2 lbs. 5

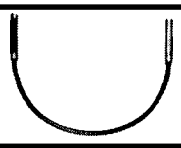

164V 17-1/2" Flexible Magnetic Pick Up Tool. Plastic gripped handle. 5



692 8-1/2" Magnetic Pick Up Tool. Hinged head contains powerful magnet. 12



694 27" Magnetic Pick Up Tool. Overall Length 27" extended, 16" closed. 12



792 Pocket Magnet Pick Up Tool. 6" Long. Pocket Clip attached. 12

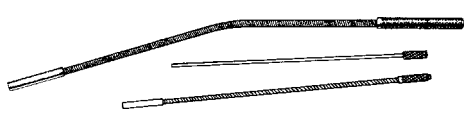



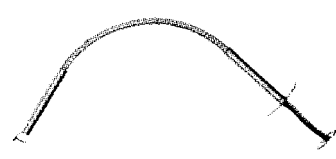

794 Flexible Magnetic Pick Up Tool. 18" Overall Length. Wire stiffening rod removable to make it completely flexible. 5/16" diameter. 12

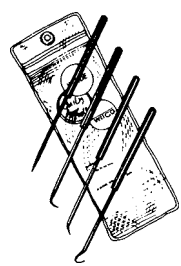

798 Flexible Mechanical Finger. Can be used as temporary clamp for small pieces. Can be bent into an "S" shape or at 90° without spring back. 15" reach. 8" flexible section. 2 Claws. 10

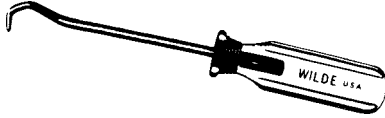

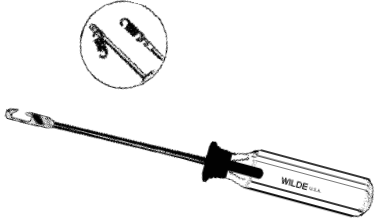
SHP904 4-Pc. Hook and Pick Set. 5

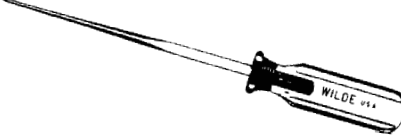
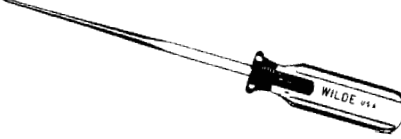
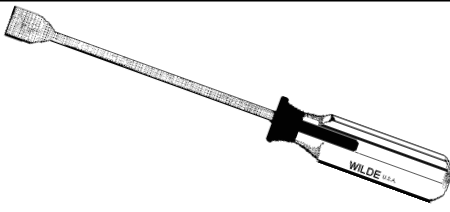
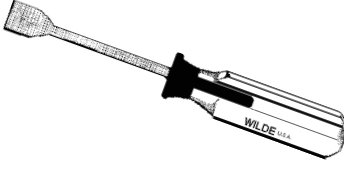
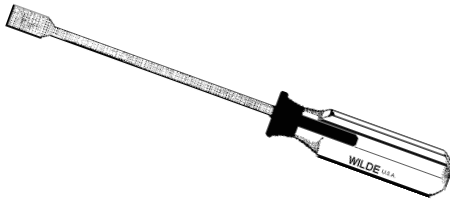
COTTER KEY EXTRACTORS		Cat.		Std.	
GASKET SCRAPERS & AWLS		No.	Description	Pk.	
	544	Cotter Key Extractor. 7" Long. Bits are forged alloy steel. Carded. "Insulite" plastic handle.	10	#'s 544, 566 & 545 series hooks/bit are not guaranteed.	
	544bit	Extra Hook for #544.	20		
	544-12	Cotter Key Extractor. 11" Long. Bits are forged alloy steel. Carded. "Insulite" plastic handle.	10		
	544-12bit	Extra Hook for #544-12B.	20		
	566	Radiator Hose Tool. Hook is made of hardened alloy steel. Carded. "Insulite" plastic handle. 7-1/4" Long.	10		
	566bit	Extra Hook for #566.	20		
	545	8" Headlight Spring Tool. Punched end for removal and replacement. "Insulite" plastic handle.	10		
   	421	11" Scratch Awl & Punch. 5/16" Bit. "Insulite" plastic handle.	10		
	442	7" Scratch Awl & Punch. 3/8" Bit. Extra heavy. "Insulite" handle.	10		
	451	5" Scratch Awl & Punch. 1/4" Bit. "Insulite" plastic handle.	10		
	452	7" Scratch Awl & Punch. 1/4" Bit. "Insulite" plastic handle.	10		
	516	11" Gasket Scraper. 8" Exposed. 1" Face. Natural Finish bit. "Insulite" plastic handle. Carded.	10		
	516bit	Bit Only for #516.	50		
	516-5	8" Gasket Scraper. 5" Exposed. 1" Face. Natural Finish bit. "Insulite" plastic handle. Carded.	10		
	516bit	Bit Only for #516-5.	50		
	516-1/2	11" Gasket Scraper. 8" Exposed. 1/2" Face. Natural Finish bit. "Insulite" plastic handle. Carded.	10		
	516-1/2bit	Bit Only for #516-1/2.	50		

PLIERS

PUNCHES, CHISELS  
& PRY BARS

WRENCHES

SCREWDRIVERS

PLUMBING &  
INDUSTRIAL

AUTOMOTIVE

SERVICE TOOLS

DISPLAYS



# SERVICE TOOLS

Cat. No. Description Std. Pk.

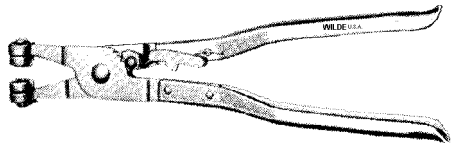

761 Hose Clamp Plier. For removing & installing spring wire hose clamps. Deep slots in jaws. Pawl automatically locks plier in any of three positions. Jaws swivel through 180°. Zinc plated. 10" Long. 5

PLIERS

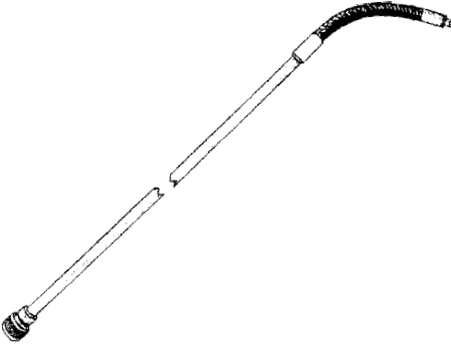

859 Flexible Driver Set contains one each of #854, 855, 856, 857 & 858. 5

PUNCHES, CHISELS & PRY BARS

WRENCHES

SCREWDRIVERS

PLUMBING & INDUSTRIAL

AUTOMOTIVE

SERVICE TOOLS

DISPLAYS

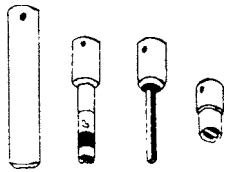

854 1/4" Drive Flexible Driver Only. 1/4" square drive to fit any 1/4" socket or attach. 21" Long, 3-1/2" Flexible section. 5

855 1/8" Hexagon Set Screw Wrench. Attachment for adjusting distributor points on GM cars. 2" Long. 5

856 Screw Driver Attachment for carburetor adjustment on most late model Ford, GM & Chrysler cars. 5

857 Screw Holding Attachment 5

858 1/2" - 1-5/8" Magnet Attachment 5



770 Contact Point File. Double cut file. High Grade steel tempered & finished. 5-1/4" Long. 10

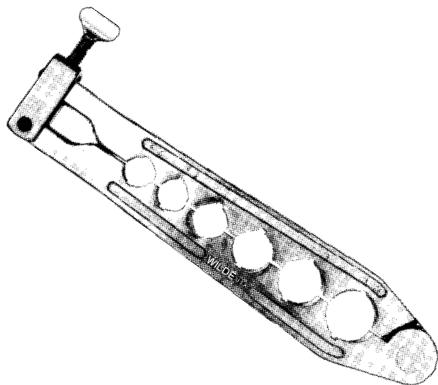

32 Axle Rethreading Die. Can be used without removing the axle from the housing. Split for quick application, is fitted to the threads at the back of the axle. Drop forged steel, heat treated. Nickel plated. Threads 3/4"-16, 3/4"-20, 7/8"-14, 1"-14, 1-1/8"-12, 1-1/4"-12. 1

# #DB6

## TOOL CENTER DISPLAY BOARD

**FREE TO THOSE CUSTOMERS WHO  
ORDER \$750.00 OR MORE.  
SIMPLY ORDER #DB6 AT NO CHARGE.**

ANY **WILDE® / WITCO®**  
DISTRIBUTOR MAY PURCHASE AT  
REGULAR DISTRIBUTOR PRICE.

HARD BLACK PLASTIC

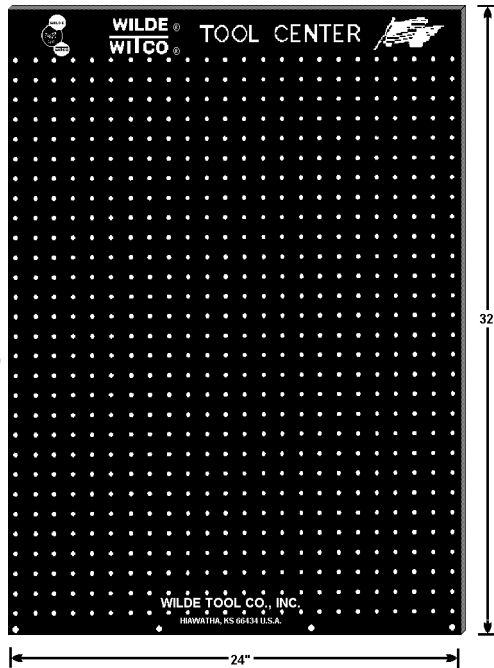

- MORE DURABLE
- 1" CENTERED HOLES
- WALL FASTENERS INCLUDED

MADE IN THE USA

ALSO

# #DB5 TOOL CENTER

**FREE TO THOSE CUSTOMERS WHO  
ORDER \$750.00 OR MORE.  
SIMPLY ORDER #DB5 AT NO CHARGE.**

- Fits all standard pegboards.
- Holes punched every square inch.
- Pegboard ASSEMBLY CLIPS supplied for hanging board.  
(pegboard hooks NOT supplied)
- Order only the tools you want.

(while supply lasts)

FLEXIBLE VINYL

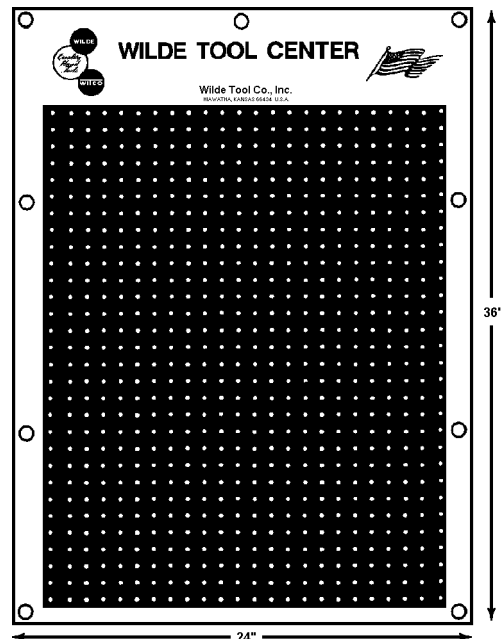

MADE IN THE USA

PLIERS

PUNCHES, CHISELS  
& PRY BARS

WRENCHES

SCREWDRIVERS

PLUMBING &  
INDUSTRIAL

AUTOMOTIVE

SERVICE TOOLS

DISPLAYS





**Wilde Tool Co., Inc.**  
HIAWATHA, KANSAS 66434 U.S.A.

**Pipe  
Wrench  
Plier**

**WILDE** U.S.A.

**WILDE** U.S.A.

**WILDE** U.S.A.

**WITCO** U.S.A.

**WITCO** U.S.A.

**WITCO** U.S.A.

**Wilde Tool Co., Inc.**  
HIAWATHA, KANSAS 66434 U.S.A.

**Wilde Tool Co., Inc.**  
HIAWATHA, KANSAS 66434 U.S.A.



**REFERENCE DATA (Decimal and Metric Equivalent of Fractions)**

	Decimal	Metric		Decimal	Metric
	$\frac{1}{64}$ — .0156	0.397		$\frac{33}{64}$ — .5156	13.097
	$\frac{1}{32}$ — .0313	.0794	$\frac{17}{32}$ — .5313		13.494
	$\frac{3}{64}$ — .0469	1.191	$\frac{35}{64}$ — .5469		13.891
$\frac{1}{16}$ — .0625		1.588	$\frac{9}{16}$ — .5625		14.288
	$\frac{5}{64}$ — .0781	1.984	$\frac{37}{64}$ — .5781		14.684
	$\frac{3}{32}$ — .0938	2.381	$\frac{19}{32}$ — .5938		15.081
	$\frac{7}{64}$ — .1094	2.778	$\frac{39}{64}$ — .6094		15.478
$\frac{1}{8}$ — .1250		3.175	$\frac{5}{8}$ — .6250		15.875
	$\frac{9}{64}$ — .1406	3.572	$\frac{41}{64}$ — .6406		16.272
	$\frac{5}{32}$ — .1562	3.969	$\frac{21}{32}$ — .6562		16.669
	$\frac{11}{64}$ — .1719	4.366	$\frac{43}{64}$ — .6719		17.066
$\frac{3}{16}$ — .1875		4.762	$\frac{11}{16}$ — .6875		17.462
	$\frac{13}{64}$ — .2031	5.159	$\frac{45}{64}$ — .7031		17.859
	$\frac{7}{32}$ — .2188	5.556	$\frac{23}{32}$ — .7188		18.256
	$\frac{15}{64}$ — .2344	5.953	$\frac{47}{64}$ — .7344		18.653
$\frac{1}{4}$ — .2500		6.350	$\frac{3}{4}$ — .7500		19.050
	$\frac{17}{64}$ — .2656	6.747	$\frac{49}{64}$ — .7656		19.447
	$\frac{9}{32}$ — .2812	7.144	$\frac{25}{32}$ — .7812		19.844
	$\frac{19}{64}$ — .2969	7.541	$\frac{51}{64}$ — .7969		20.241
$\frac{5}{16}$ — .3125		7.938	$\frac{13}{16}$ — .8125		20.638
	$\frac{21}{64}$ — .3281	8.334	$\frac{53}{64}$ — .8281		21.034
	$\frac{11}{32}$ — .3438	8.731	$\frac{27}{32}$ — .8438		21.431
	$\frac{23}{64}$ — .3594	9.128	$\frac{55}{64}$ — .8594		21.828
$\frac{3}{8}$ — .3750		9.525	$\frac{7}{8}$ — .8750		22.225
	$\frac{25}{64}$ — .3906	9.922	$\frac{57}{64}$ — .8906		22.822
	$\frac{13}{32}$ — .4062	10.319	$\frac{29}{32}$ — .9062		23.019
	$\frac{27}{64}$ — .4219	10.716	$\frac{59}{64}$ — .9219		23.416
$\frac{7}{16}$ — .4375		11.112	$\frac{15}{16}$ — .9375		23.812
	$\frac{29}{64}$ — .4531	11.509	$\frac{61}{64}$ — .9531		24.209
	$\frac{15}{32}$ — .4688	11.906	$\frac{31}{32}$ — .9688		24.606
	$\frac{31}{64}$ — .4844	12.303	$\frac{63}{64}$ — .9844		25.003
$\frac{1}{2}$ — .5000		12.700	1 — 1.000		25.400



Dear Wilde/Witco Customer:

We appreciate your interest in our quality hand tool line. To serve your needs this form is for your use in ordering additional literature, **FREE OF CHARGE.**



Quantity Item

\_\_\_\_\_ Wilde's current Distributor Price List. (We cannot ship if we do not have your resale tax number.)  
(Current Distributors - Disregard.) # \_\_\_\_\_

\_\_\_\_\_ Wilde's current List Price List.

\_\_\_\_\_ Wilde's No-Price Catalog.

- Sales Brochure and Re-Order Form for sales literature.
- Please have your inside sales person telephone me.
- Please have your local sales representative call on me.
- Please forward me a list of Wilde Distributors in my area.

**WILDE**® U.S.A.

**WITCO**® U.S.A.



**Wilde Tool Co., Inc.**

HIAWATHA, KANSAS 66434 U.S.A.

C/LR1 6-2001

Company: \_\_\_\_\_ Street Zip (If Different)

Street Address: \_\_\_\_\_

P.O. Box: \_\_\_\_\_

City/State/Zip: \_\_\_\_\_

Attn: \_\_\_\_\_ email: \_\_\_\_\_

Telephone: ( ) \_\_\_\_\_ Fax: ( ) \_\_\_\_\_

Dear Wilde/Witco Customer:

We appreciate your interest in our quality hand tool line. To serve your needs this form is for your use in ordering additional literature, **FREE OF CHARGE.**



Quantity Item

\_\_\_\_\_ Wilde's current Distributor Price List. (We cannot ship if we do not have your resale tax number.)  
(Current Distributors - Disregard.) # \_\_\_\_\_

\_\_\_\_\_ Wilde's current List Price List.

\_\_\_\_\_ Wilde's No-Price Catalog.

- Sales Brochure and Re-Order Form for sales literature.
- Please have your inside sales person telephone me.
- Please have your local sales representative call on me.
- Please forward me a list of Wilde Distributors in my area.

**WILDE**® U.S.A.

**WITCO**® U.S.A.



**Wilde Tool Co., Inc.**

HIAWATHA, KANSAS 66434 U.S.A.

C/LR1 6-2001

Company: \_\_\_\_\_ Street Zip (If Different)

Street Address: \_\_\_\_\_

P.O. Box: \_\_\_\_\_

City/State/Zip: \_\_\_\_\_

Attn: \_\_\_\_\_ email: \_\_\_\_\_

Telephone: ( ) \_\_\_\_\_ Fax: ( ) \_\_\_\_\_

# NOTES

# NUMERICAL INDEX

Cat. No.	Pg. No.	Cat. No.	Pg. No.	Cat. No.	Pg. No.	Cat. No.	Pg. No.	Cat. No.	Pg. No.	Cat. No.	Pg. No.	Cat. No.	Pg. No.
1SN	55	97	53	<b>452</b>	71	<b>544-12bit</b>	71	910B	52	12912	30		
2CP	54	98	53	453	51	<b>545</b>	71	911B	52	13103	31		
2DF	54	99	53	476	65	553	51	912B	52	13104	31		
2-1/2DF	54	142	69	499	35, 65	563	15	913B	52	13106	31		
2SN	55	142-1	69	500	65	564	15	914B	52	13107	31		
3CP	54	143	69	501	65	<b>566</b>	71	950	62	13150	31		
3DF	54	143A	69	504	65	<b>566bit</b>	71	951	62	13160	31		
3SN	55	143-1	69	510	65	<b>577-NP</b>	11	952	62	13170	31		
4CP	54	144	51	512B-.003	64	<b>577B</b>	11	953	62	13181	31		
4DF	54	144T	51	512B-.004	64	<b>577T-NP</b>	11	954	62	13182	31		
4SN	55	145	69	512B-.005	64	<b>577TB</b>	11	955	62	13212	31		
4VGR	10	147A	69	512B-.006	64	578	65	956	62	13214	31		
<b>5S</b>	8	147A-1	69	512B-.007	64	579	65	957	62	13216	31		
5SN	55	151	69	512B-.008	64	<b>587T-NP</b>	11	958	63	13218	31		
6DF	54	151-1	69	512B-.009	64	<b>587TB</b>	11	959	63	13220	31		
<b>6N</b>	8	151P	69	512B-.010	64	589	65	962	63	13222	31		
6SN	55	152	69	512B-.011	64	600	60	964	63	13224	31		
6VGR	10	152-1	69	512B-.012	64	600-3A	60	990	37	13226	31		
<b>7G</b>	8	<b>156R</b>	35	512B-.013	64	600-3B	60	1001	53	13312	31		
<b>7VGR</b>	10	157	69	512B-.014	64	606E	52	1002	53	13312X	32		
8DF	54	157A	69	512B-.015	64	607E	52	1003	53	13314	31		
<b>8N</b>	8	157-1	69	512B-.016	64	608 - PR.	60	1004	53	13314X	32		
8SN	55	158A	70	512B-.017	64	608E	52	1005	53	13316	31		
9SN	55	<b>158R</b>	35	512B-.018	64	609E	52	1006	53	13316X	32		
9VGR	10	159A	70	512B-.019	64	610E	52	1008	53	13318	31		
10DF	54	<b>159R</b>	35	512B-.020	64	612 - PR.	60	1016	53	13318X	32		
<b>10S</b>	8	<b>160R</b>	35	512B-.021	64	612E	52	1032	53	13320	31		
10SN	55	162V	70	512B-.022	64	613C - PR.	60	1080	53	13320X	32		
10VGR	10	<b>164R</b>	35	512B-.023	64	614E	52	1214	15	13322	31		
<b>11S</b>	8	164V	70	512B-.024	64	615	60	1234	15	13322X	32		
12DF	54	175	45	512B-.025	64	616E	52	1500	48	13324	31		
20DF	54	175A	45	512B-.026	64	620E	52	1501	48	13324X	32		
31	64	189	34	512B-.027	64	624E	52	1507	48	13326	31		
<b>32</b>	72	190	34	512B-.028	64	653	51	1510	48	13328	31		
<b>33P</b>	48	191	34	512BE-.0015	64	656	45	<b>1718</b>	35	13412	32		
44	64	192	34	512BE-.002	64	657	45	<b>1719</b>	35	13414	32		
44-2	64	193	34	512BL-.030	64	658	45	<b>1720</b>	35	13416	32		
47	64	194	34	512BL-.032	64	692	70	<b>1721</b>	35	13418	32		
47A	64	195	34	512BL-.035	64	694	70	1722	35	13420	32		
48	64	196	34	512BL-.040	64	700	61	1723	35	13422	32		
49	64	197	34	515	61	761	72	1724	35	13424	32		
51	64	198	34	516	71	770	72	1725	35	13426	32		
52R	52	199	34	<b>516bit</b>	71	792	70	1726	35	13428	32		
53R	52	200	50	<b>516-1/2</b>	71	794	70	1727	35	13512	32		
55	52	201	34	<b>516-1/2bit</b>	71	798	70	1728	35	13514	32		
55A	52	202	34	<b>516-5</b>	71	800	38	3870	48	13516	32		
56	52	203	34	<b>516-5bit</b>	71	801	38	4225	9	13518	32		
57	52	<b>204</b>	35	517	15	802	38	4226	9	13520	32		
58	52	<b>205</b>	35	517TS	15	803	38	4227	9	13522	32		
59	52	<b>206</b>	35	517T-45	15	804	38	4240	9	13524	32		
60	52	<b>207</b>	35	517T-90	15	805	38	4256	9	13526	32		
60DGS	59	208	34	518	15	806	38	4256	9	13528	32		
61	52	208B	34	520	14	807	39	4276	9	13528	32		
61DG	59	209	34	520A	14	810	39	4278	9	13620	31		
61-1S	59	209B	34	520B	14	811	39	4287	9	13626	31		
61-2S	59	210	34	521	14	812	39	4296	9	14102	33		
61-4S	59	210B	34	521A	14	813	39	4297	9	14105	33		
62	52	218	51	521B	14	814	39	4298	9	14110	33		
62DG	59	224	51	522	14	815	39	4299	9	14150	33		
62DGS	59	232	51	522A	14	816	39	4756	9	14160	33		
62-2S	59	250DF	50	522B	14	817	39	8954	35	14161	33		
62-4S	59	300	50	523	14	854	72	9033D	49	14170	33		
63	52	300W	50	523A	14	855	72	9106E	52	14181	33		
63DG	58	301S	68	523B	14	856	72	9139B	52	14312	33		
63-1	58	301-3S	68	524	14	857	72	12000	28	14314	33		
63-14	58	302S	68	524A	14	858	72	12001	28	14316	33		
63-21	58	302-3S	68	525	14	859	72	12002	29	14318	33		
63-24	58	303S	68	525A	14	862	37	12003	28	14320	33		
63-34	58	303-3S	68	526	14	863	37	12004	29	14322	33		
63-100	58	321S	68	526A	14	864	37	12005	29	14324	33		
64FDG	58	325	50	526B	14	865	37	12102	30	14326	33		
64-1	58	325W	50	527	14	866	37	12106	30	14328	33		
64-14	58	350	50	527A	14	867	37	12106	30	14330	33		
66	64	350W	50	527B	14	868	37	12150	30	14332	33		
67	64	380	49	528	14	870	37	12170	30	14334	33		
67DG	58	383	49	528A	14	871	37	12180	30	14336	33		
68	58	385	49	528B	14	873	36	12206	30	14338	33		
68A	58	400-45	50	534	14	874	36	12207	30	14340	33		
69	64	400-AD	50	534A	14	875	36	12208	30	21900	35		
81	44	<b>406-NP</b>	11	535	14	876	36	12209	30	52204	30		
82	44	418	51	535A	14	877	36	12210	30	52245	30		
83	44	<b>421</b>	71	535B	14	878	36	12211	30	52205	30		
84	44	424	51	537	16	879	36	12212	30	52255	30		
85	44	<b>426-NP</b>	11	538	16	880	36	12214	30	52206	30		
86	44	<b>426B</b>	11	540	16	881	36	12216	30	52207	30		
87	44	<b>427-NP</b>	11	541	16	883	36	12406	30	52208	30		
88	44	<b>427B</b>	11	542	15	885	36	12407	30	52209	30		
89	53	432	51	<b>544</b>	71	900	37	12408	30	52210	30		
90	53	<b>442</b>	71	<b>544bit</b>	71	902B	52	12409	30	53207	32		
91	53	444E	15	<b>544-12</b>	71	903B	52	12410	30	53208	32		
92	53	444I	15			904B	52	12411	30	53209	32		
93	53	444K	15			905B	52	12412	30	53210	32		
94	53	444T	15			906B	52	12414	30	53211	32		
95	53					907B	52	12416	30	53212	32		
96	53	<b>451</b>	71			908B	52	12606	30	53213	32		
						909B	52	12908	30	53214	32		
								12910	30	53215	32		

# NUMERICAL INDEX

Cat. No.	Pg. No.	Cat. No.	Pg. No.	Cat. No.	Pg. No.	Cat. No.	Pg. No.	Cat. No.	Pg. No.
53216	32	CCL3232-18B	18	G292SPB	13	PC1632B	21	PS1032B	21
53217	32	CD432	18	G292SPD	13	PC2032	21	PS1232	21
53218	32	CD432B	18	G293P-NP	5	PC2032B	21	PS1232B	21
53219	32	CD532	18	G293B	5	PLT5	23	PW8	49
53307	32	CD532B	18	G295P-NP	5	PLT232	20	PW10	49
53308	32	CD632	18	G295B	5	PLT232B	20	PW14	49
53309	32	CD632B	18	G297P-NP	5	PLT332	20	PW18	49
53310	32	CD832	18	G297B	5	PLT332B	20	PW24	49
53311	32	CD832B	18	G297SP	13	PLT432	20	PW36	49
53312	32	CD1032	18	G299P-NP	5	PLT432B	20	RB2432	19
53313	32	CD1032B	18	G299B	5	PLT532	20	RB2432B	19
53314	32	CD1232	18	G299SP	13	PLT532B	20	RHL232-9	22
53315	32	CD1232B	18	G404P-NP	11	PLT632	20	RHL232-9B	22
53316	32	CD1632	18	G404B	11	PLT632B	20	RHL632-12	22
53317	32	CD1632B	18	G410P-NP	10	PLT732	20	RHL632-12B	22
53318	32	CD2032	18	G410B	10	PLT732B	20	RHL632	22
53319	32	CD2032B	18	G428N-NP	8	PLT832	20	RHL632B	22
902131	31	CP632	19	G704P-NP	11	PLT832B	20	RH2032	22
902136	31	CP632B	19	G704B	11	PLT932	20	RH2032B	22
902141	33	CP732	19	G705B	11	PLT932B	20	RS232	25
903121	30	CP732B	19	HPB1232-7B	22	PLT1032	20	RS564	25
903129	30	CP832	19	HPB1232-12B	22	PLT1032B	20	RS332	25
903141	33	CP832B	19	HPB1632-18B	22	PLT1232	20	RS432	25
904131	31	CP1032	19	HPB1632-24B	22	PLT1232B	20	RS532	25
907133X	32	CP1032B	19	HPB2032-28B	22	PP5	23	RS632	25
908132	31	CP1232	19	HPB3B	22	PP232	20	RS732	25
909122	30	CP1232B	19	JB1632	22	PP232B	20	RS832	25
909124	30	CR432	19	JB1632B	22	PP564	20	RS1032	25
909134	32	CR432B	19	JB2032	22	PP564B	20	RS1232	25
909135	32	CR632	19	JB2032B	22	PP332	20	RS1432	25
909522	30	CR632B	19	JB2432	22	PP332B	20	RS1632	25
911133	31	CR732	19	JB2432B	22	PP432	20	RS906	25
913532	32	CR732B	19	JB2432-24	22	PP432B	20	RS912	25
913533	32	CR832	19	JB2432-24B	22	PP532	20	S14	42
915143	33	CR832B	19	JB2832	22	PP532B	20	S22	42
A67	12	CR1032	19	JB2832B	22	PP632	20	S25	42
AWB4	40	CR1032B	19	K5	24	PP632B	20	S42	42
AWB6	40	CR1232	19	K8	24	PP732	20	S43	42
AWB8	40	CR1232B	19	K12	24	PP732B	20	S44	42
AWB10	40	CR1632	19	K20	24	PP832	20	S46	42
AWB12	40	CR1632B	19	LB632	21	PP832B	20	S64	42
AWB15	40	DB5	73	LB632B	21	PP1032	20	S83	42
AWB18	40	DB6	73	LB732	21	PP1032B	20	S85	42
AWB24	40	G6	24	LB732B	21	PP1232	20	S86	42
AWC4	40	G6N	8	LB832	21	PP1232B	20	S104	42
AWC6	40	G8N	8	LB832B	21	PPL4	23	S126	42
AWC8	40	G250P-NP	6	LB1032	21	PPL432	20	SHP904	70
AWC10	40	G250B	6	LB1032B	21	PPL432B	20	SMC6	34
AWC12	40	G251P-NP	6	MC10	34	PPL532	20	SMC6B	34
AWC15	40	G251B	6	MC11	34	PPL532B	20	SMC10	34
AWC18	40	G252P-NP	6	MC12	34	PPL632	20	SMC10B	34
AWC24	40	G252B	6	MC13	34	PPL632B	20	SMD910	44
CC5	23	G253P-NP	6	MC14	34	PPL732	20	SW2	43
CC9	23	G253B	6	MC15	34	PPL732B	20	SW2-1S	43
CC832	18	G254P-NP	6	MC16	34	PPL832	20	SW2-2L	43
CC832B	18	G254B	6	MC17	34	PPL832B	20	SW4	43
CC1032	18	G256SPD	12	MC18	34	PPL1032	20	SW4-1S	43
CC1032B	18	G258SPD	12	MC19	34	PPL1032B	20	SW4-2L	43
CC1232	18	G259SPD	12	MD4	44	PPL132B	20	SW4-T15	43
CC1232B	18	G260P-NP	7	MD45	44	PPL1232B	20	SW4-T25	43
CC1432	18	G260B	7	MD5	44	PR832	21	SW4-R	43
CC1432B	18	G261BP-NP	7	MD55	44	PR832B	21	SW7	43
CC1632	18	G261BB	7	MD6	44	PR1032	21	SW7-1	43
CC1632B	18	G261TB	7	MD7	44	PR1032B	21	SW7-2	43
CC2032	18	G262P-NP	7	MD8	44	PR1632	21	SW7-3	43
CC2032B	18	G262B	7	MD9	44	PR1632B	21	SW7-4	43
CC2432	18	G263P-NP	7	MD10	44	PR1232	21	SW7-5	43
CC2432B	18	G263B	7	MD11	44	PR1232B	21	SW7-6	43
CC2832	18	G264P-NP	7	P142	42	PR1632	21	SW7-7	43
CC2832B	18	G264B	7	P220	42	PR1632B	21	SW8	43
CC3232	18	G269P-NP	4	P331	42	PS232	21	SW9	43
CC3232B	18	G269B	4	P442	42	PS232B	21	SW10	43
CC3632	18	G270P-NP	4	P653	42	PS332	21	T10	45
CC3632B	18	G270B	4	PB2032	22	PS332B	21	T15	45
CC4	23	G271P-NP	4	PB2032B	22	PS432	21	T20	45
CCL1632	18	G271B	4	PB2432	22	PS432B	21	T25	45
CCL1632B	18	G272P-NP	4	PB2432B	22	PS532	21	T27	45
CCL2032	18	G272B	4	PC832	21	PS532B	21	T30	45
CCL2032B	18	G274P-NP	4	PC832B	21	PS632	21	TS35	45
CCL2432	18	G274B	4	PC1032	21	PS632B	21		
CCL2432-14	18	G276P-NP	4	PC1032B	21	PS732	21		
CCL2432-14B	18	G276B	4	PC1232	21	PS732B	21		
CCL2432-18	18			PC1232B	21	PS832	21		
CCL2432-18B	18			PC1432	21	PS832B	21		
CCL2832	18			PC1432B	21	PS1032	21		
CCL2832B	18			PC1632	21				
CCL3232	18								
CCL3232B	18								
CCL3232-18	18								